

## Models and major assemblies

	Model	Engine	Automatic 7-speed transmission
SLK 350	171.456	272.963	722.906
SLK 55 AMG	171.473	113.989	722.907

## Brief description

### Vehicle concept

The SLK's dynamic appearance is emphasized by a longer wheelbase than its predecessor, in conjunction with short overhangs at the front and rear and new styling elements.

Besides the innovative retractable roof numerous body components, the majority of which are new developments, contribute to the car's high standards of sporty comfort and safety. With its advanced retractable roof, the SLK is a coupé and a roadster in one.

The mechanism and space-saving storage of the retractable roof in the trunk has been optimized even further. The retractable roof opens and closes at the touch of a button. Within approx. 22 secs. the SLK transforms itself into a classic coupé with all the associated advantages in terms of aerodynamics, aeroacoustics and safety.



*SLK roadster*

## Brief description

### Dimensional drawing

In comparison with model series 170, the dimensions of the new SLK have been altered in several respects.

In terms of external dimensions, model series 171 is 2.8" longer, 2.6" wider and 0.8" taller. Its wheelbase has grown by 1.2", its front track width by 1.4" and its rear track width by 2.6".

These modified proportions help to lend the new SLK its dynamic appearance.

The interior compartment has been further optimized. The seat adjustment range has been increased in the horizontal direction from 7.7" to 8.3".

As the vehicle is 0.6" taller, the height of the trunk has been increased by 1" to 38". One of the main benefits is that the front roof frame has been moved upwards relative to the driver.

In spite of its longer wheelbase, the turning circle is reduced by approx. 2.8" to 34.5'.

### Innovations at a glance

- Retractable roof with pivoting rear window
- Large trunk capacity
- Improved deformation resistance in collision due to high-strength passenger cell
- Optional bi-xenon headlamps with cornering fog lamps (not available for AMG styling and SLK 55 AMG)
- Roll bars
- Restraint systems with improved detection
- V6-cylinder engine with a displacement of 3.5 l
- AMG 8-cylinder naturally aspirated engine with a displacement of 5.5 l
- AMG high-performance brake system with 6-piston fixed calipers and compound brake disks at the front and 4-piston fixed calipers and internally ventilated brake disks at the rear
- Sports seats with all-round magnesium frame
- Optimized climate control in terms of draft-proofing, low noise emission and effectiveness
- Rear storage compartment (between the seats on the rear wall)
- Audio and communications systems (COMAND) and Motorola cellular telephone

### Highlights at a glance

- AIRSCARF neck-level heating (optional equipment)
- Newly developed 7-speed automatic transmission (optional equipment)
- Head/thorax air bags in the outboard sides of the backrests
- New front end
- Optional tire pressure loss warning system
- 2-arm windshield wipers with wiper on the front passenger side

## Brief description



P00.00-3560-00

*SLK with closed roof (shown with accessory wheels)*



P00.00-3593-00

*SLK retractable roof movement sequence (shown with accessory wheels)*



P00.00-3559-00

*SLK with open roof (shown with accessory wheels)*

## Equipment

	SLK 350	SLK 55 AMG
<b>Brake system, drive train</b>		
4-piston fixed caliper brake (front)	Standard	—
2-piston fixed caliper brake (rear)	Standard	—
AMG 6-piston fixed caliper brake with compound brake disk (front)	—	Standard
AMG 4-piston fixed caliper brake with internally ventilated brake disk (rear)	—	Standard
Vehicle dynamics control systems ABS, BAS and ESP II	Standard	
6-speed manual transmission	Standard	—
7-speed automatic transmission (including steering wheel gear shift)	Optional equipment	—
AMG SPEEDSHIFT 7-speed automatic transmission (including steering wheel gear shift)	—	Standard

## Equipment

	SLK 350	SLK 55 AMG
<b>Chassis</b>		
Front axle: 3-link axle (MacPherson)	Standard	
Rear axle: MB independent multilink suspension	Standard	
Lowered sports suspension	Optional equipment	–
AMG sports suspension	–	Standard
<b>Steering</b>		
Rack-and-pinion steering	Standard	
Speed-sensitive power steering	Optional equipment	
Manual steering column longitudinal and vertical adjustment	Standard	-
Electric steering column longitudinal and vertical adjustment with easy entry function (memory function)	Optional equipment	Standard

## Equipment

	SLK 350	SLK 55
<b>Wheels, tires and light alloy wheels</b>		
Front axle: Standard suspension	225/45 R 17 on 7.5J x 17 ET 36	225/40 R 18 on 7.5J x 18 ET 37
Rear axle: Standard suspension	245/40 R 17 on 8.5J x 17 ET 30	245/35 R 18 on 8.5J x 18 ET 30
AMG 18" light alloy wheel with 5-spoke design (painted in sterling silver)	–	Optional equipment (at no extra cost)
AMG 18" light alloy wheel with multi-spoke design (16 spokes, polished)	–	Standard
Available M&S winter tires <sup>1)</sup> approved for snow chains	225/45 R 17 on 7.5J x 17 ET 36	205/50R 17 <sup>1)</sup> on 7J x 17 ET 37 or 225/45 R 17 <sup>1)</sup> on 7.5J x 17 ET 37 or 225/40 R 18 <sup>1)</sup> on 7.5J x 18 ET 37

## Equipment

	SLK 350	SLK 55 AMG
<b>Safety and anti-theft protection</b>		
Head/thorax air bags in the front seat backrests	Standard	
Fixed upright roll bars	Standard	
MOExtended (Mercedes-Benz Original Extended) tires with emergency run flat characteristics (not for AMG 18" light alloy wheel [optional equipment]) with tire pressure loss warning system	Optional equipment (Delayed availability)	—
Emergency tensioning devices and 2-stage belt force limiters	Standard	
Dual stage driver and passenger air bags with 2 deployment thresholds	Standard	
Locking system with remote control	Standard	



## Equipment

	SLK 350	SLK 55 AMG
<b>Safety and anti-theft protection</b>		
Convenience locking system with infrared remote control for the retractable hardtop	Optional equipment	Standard
Anti-theft alarm system (ATA)	Standard	
<b>Climate control/Automatic Climate Control</b>		
Climate control	Standard	
Automatic climate control	Optional equipment	
AIRSCARF neck level heating (optional with heated seats)	Optional equipment	
Heated seats	Optional equipment	Standard

## Equipment

	SLK 350	SLK 55 AMG
<b>Aerodynamics</b>		
AMG rear mounted spoiler	–	Standard
Additional longitudinal fins on hood, silver-painted	–	Standard
Lateral fin in radiator grille, black-painted	–	Standard
<b>Light systems</b>		
Bi-xenon headlamps with cornering fog lamps (not available for AMG styling and SLK 55 AMG)	Optional equipment	
Halogen headlamps	Standard	
Interior ambient light package	Optional equipment	Standard
LED taillamps	Standard	
Tinted rear lamps and tinted center high-mounted stop lamp	–	Standard

## Equipment

	SLK 350	SLK 55 AMG
<b>Convenience systems</b>		
Cruise control	Standard	
Retractable hardtop, electrohydraulic with heated rear window	Standard	
Automatically dimming inside rearview mirror and outside mirror (left)	Optional equipment	Standard
Garage door opener in overhead control panel	Optional equipment	
Draft stop, textile version	Standard	
Rear storage compartment (on the rear wall between the seats)	Standard	
Coat hanger hook on the rear of the front seats	Standard	

## Equipment

	SLK 350	SLK 55 AMG
<b>Convenience systems</b>		
Armrest with compartment (SLK 55 AMG: armrest top covered in nappa leather)	Standard	
3-spoke multifunction steering wheel in leather	Standard	–
AMG ergonomic sport steering wheel with shift buttons	–	Standard
AMG instrument cluster (200 mph scale, AMG logo and V8 logo in tachometer)	–	Standard
8-way power front seats with 3-position memory function and power adjustable steering column with memory and outside mirrors	Optional equipment	Standard
Longitudinal and vertical seat adjustment and backrest angle all mechanical	Standard	
Belt guide on the seat	Standard	

## Equipment

	SLK 350	SLK 55 AMG
<b>Telephone, audio and communications systems</b>		
Audio 20 CD radio	Standard equipment	
CD changer in glove compartment	Optional equipment	
harman/kardon Logic 7 digital surround sound system with 11 speakers	Optional equipment	
Integrated Motorola Digital telephone	Optional equipment	
COMAND with DVD navigation	Optional equipment	
Tele Aid	Standard equipment	
Antenna for radio on rear fender	Standard	

### AMG styling

The AMG styling package is available for the SLK 350 as optional equipment. Its characteristic features include the front apron with front fog lamps framed by chrome rings, side sill panel trim covers and the rear apron with its black insert (diffusor look).

### SLK 55 AMG

The high-performance roadster has a unique frontal aspect:

- Specific front apron with side air outlets
- Air inlet grilles on both sides and in the center
- Silver-painted longitudinal fins on the hood
- Black-painted lateral fins in the radiator grille

The tail of the AMG roadster also differs from that of the production version:

- Trunk lid with AMG spoiler

- AMG rear apron with diffusor look
- Tinted rear lamps and tinted center high-mounted stop lamp
- AMG sports exhaust system with twin chrome-plated tailpipes

The AMG roadster is fitted with AMG 18" multi-spoke light alloy wheels as standard equipment. Alternatively (as optional equipment at no extra cost), AMG 18" light alloy wheels in the new 5-spoke design are available. The AMG-specific side sill panel trim covers emphasize the vehicle's strikingly sporty style.



*Front view of SLK 55 AMG*

# Dimensions

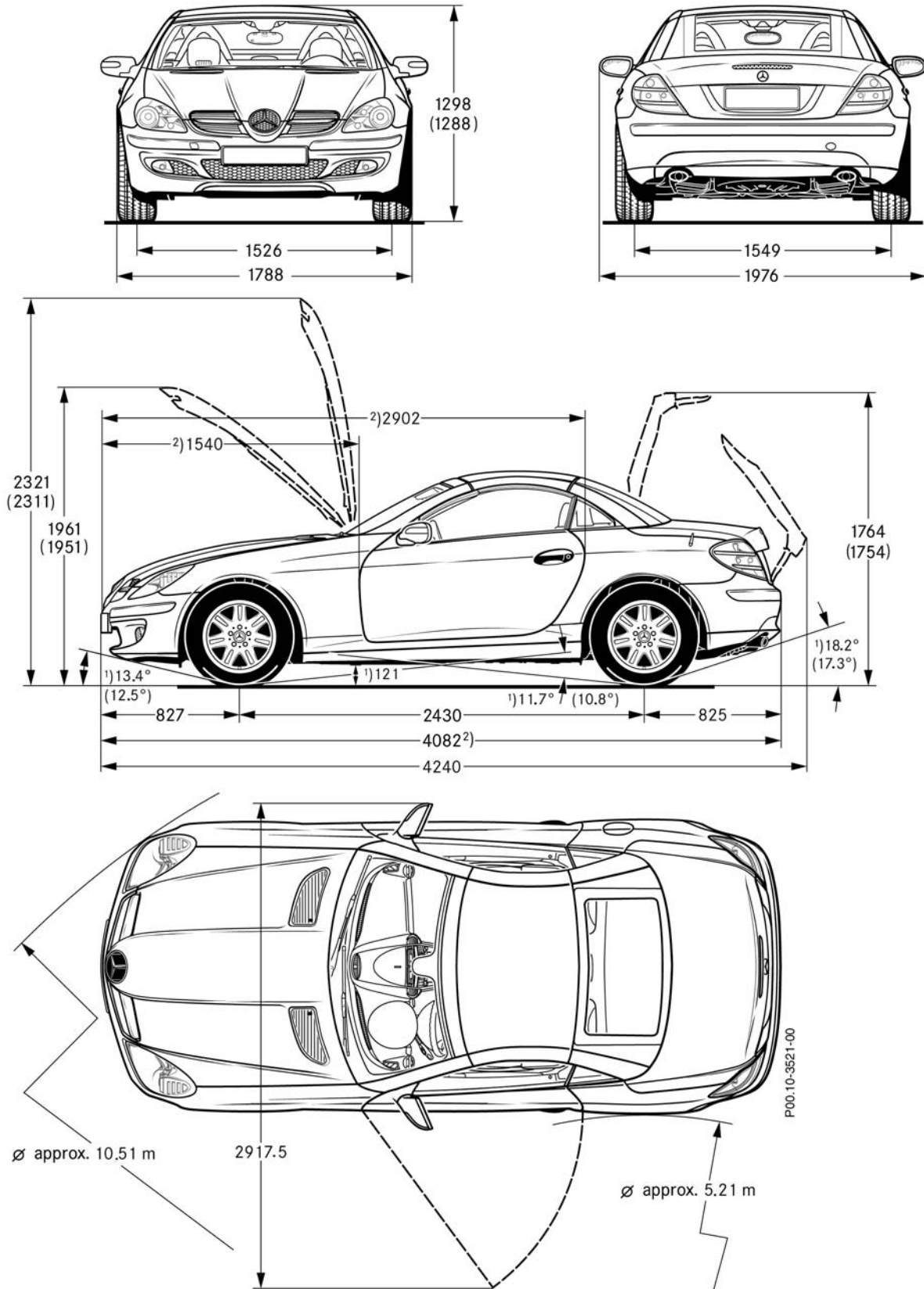

**Vehicle dimensions (shown with non-US wheels)**

<sup>1</sup> Loaded with 2 persons of 75 kg each

<sup>2</sup> Dimension without license plate adapter (7 mm)

(...) Vehicles with sports suspension  
Dimensions unloaded

# Dimensions

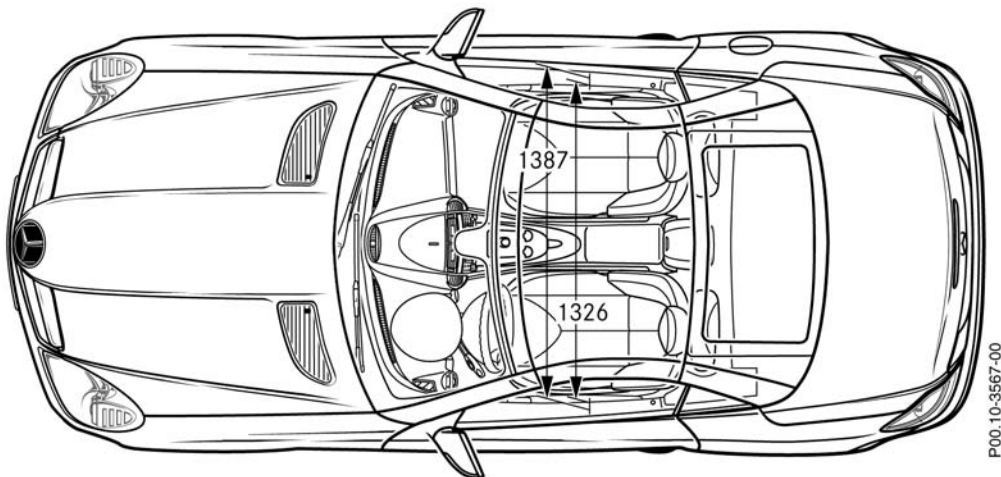
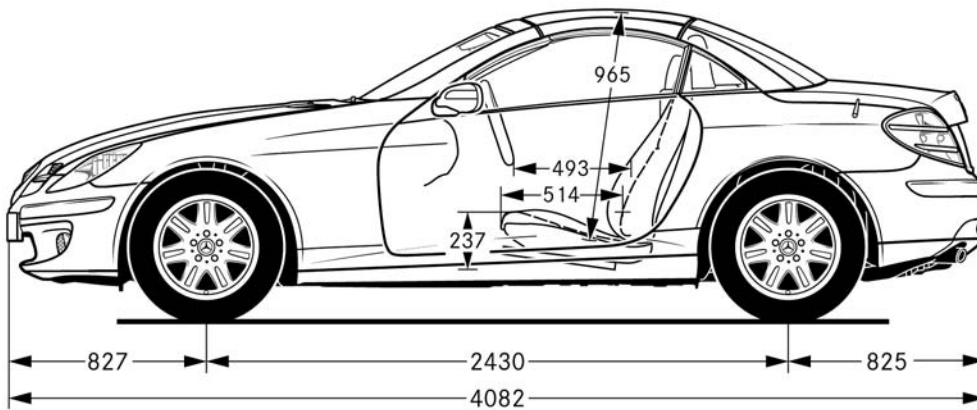
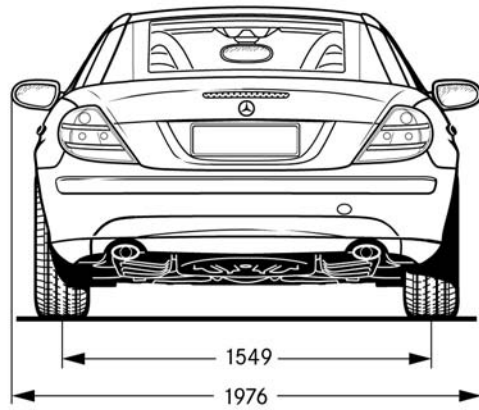
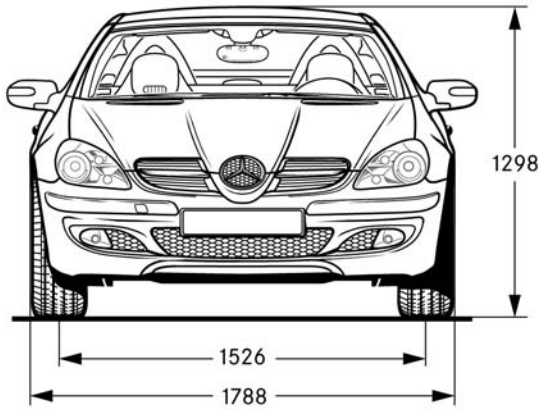

P00.10-3567-00

**Vehicle dimensions (shown with non-US wheels)**

*Dimension without license plate adapter (7 mm)*

*Dimensions unloaded*



## Technical data

		SLK 350	SLK 55 AMG
<b>Dimensions and weights</b>			
Curb weight as per DIN	kg	1465	1540
Permissible gross vehicle weight	kg	1780	1850
Payload	kg	315	310
Max. seating capacity		2	
Trunk capacity (with closed roof)	l	277	
Trunk capacity (with open roof)	l	185	
Turning circle	m	10.51	
Tank capacity	l	70	

## Exterior colors

### Exterior colors

The exterior colors available for the SLK are three standard<sup>1</sup> and eight optional metallic<sup>2</sup> finishes as well as one exclusive SLK color<sup>3</sup>.

Color no. MB	Designation
590	Mars red <sup>1</sup>
040	Black <sup>1</sup>
960	Alabaster white <sup>1</sup>
548	Firemist red <sup>2</sup>
345	Orion blue <sup>2</sup>
359	Capri blue <sup>2</sup>
816	Everest green <sup>2</sup>
762	Diamond silver <sup>2</sup>
775	Iridium silver <sup>2</sup>
197	Obsidian black <sup>2</sup>
950	Caspian blue <sup>2,3</sup>
723	Pewter <sup>2</sup> (launch edition only, cannot be ordered except with launch edition)

## Active safety

In comparison with the predecessor model series, numerous components have been redeveloped for even better active safety:

- Handling and stability
- Visibility
- Ergonomic features
- Stress-reducing features

The improvement in handling and stability are largely due to:

- 3-link front axle
- Optimized independent multilink rear suspension
- Rack-and-pinion steering gear
- Tire pressure loss warning system (optional)

The newly developed components which help to improve visibility include:

- Projection headlamps with automatic driving light actuation at night and in tunnels
- Bi-Xenon headlamps (optional equipment) with cornering fog lamps (cornering fog lamps function not available for AMG styling and SLK 55 AMG)
- Narrower A-pillar for an improved view
- 2-arm windshield wipers with excentric sweep arm on the front passenger side too

Ergonomics are improved by:

- Ergonomic controls for the communications and information systems
- Multifunction steering wheel including thumb rest
- Clearly readable antiglare instruments

The improved stress-reducing features:

- New, more comfortable seats
- Automatic Climate Control (ACC) (optional)



*Multifunction steering wheel with instrument cluster*

## Passive safety

### Passive safety

The high safety standard of the predecessor model has been further improved in the new SLK with addition of the newly developed restraint systems and the car's higher static and dynamic structural strength and durability:

- Occupants are supported by a roadster-specific frame floor system with B-pillar stumps, a high-strength A-pillar assembly and a deformable hybrid steering wheel
- Optimized lightweight steel construction combined with high-strength structural components in the front end and side walls for outstanding crash performance
- Generous crumple zones at the rear, fuel tank and filler neck located above the rear axle, box-shaped rear longitudinal members and steel spare wheel well

The safety-relevant restraint systems for the driver and the front passenger have also been developed further. Notable additions on the new SLK are:

- Two-stage, adaptive inflation of the optimized air bag
- 3-point seat belts with buckle emergency tensioning devices and a two-stage, adaptive belt force limiting function
- Head/thorax air bags in the outsides of the backrests

One important factor needed for optimized air bag was the further expansion of the sensor systems with appropriate software adjustments for the restraint systems control module to improve detection of the accident type and severity.

These include:

- Two upfront sensors in the frontal area for quicker sensing of the accident severity
- A rollover sensor

## Aerodynamic drag

The amount of lift at the front and rear axles has an influence on directional stability and road adhesion, and thus affects active safety. Front and rear axle lift in model series 171 has been substantially reduced in comparison with the predecessor model.

Its remarkably low drag coefficient of 0.34 for SLK 350 was achieved by the following measures:

- Steeply raked front end
- More steeply raked windshield
- An all-round air flow breakaway edge at the rear
- Wheel spoilers in front of the front and rear wheels
- A fully enclosed engine compartment and underbody
- Optimized rocker panel covers
- Redesigned outside mirrors

## Aeroacoustics

Precision optimization of the retractable roof has produced a further reduction in wind noise. The new outside mirrors play a significant role in this: Their external dimensions have been reduced and the drain lip on the underside of the housing (which was previously required to help keep the mirror clean) is no longer necessary. In terms of aeroacoustics, the retractable roof has further extended the SLK's existing head start over roadsters with soft tops.



*Airflow with retractable roof open*

## Lighting

### Halogen projection system

The halogen projection system consists of the following equipment:

- On the outside the lens optics with an H7 bulb for the low beam
- Beside this a reflector with a yellow bulb for the turn signal
- Underneath, a reflector with an H7 bulb for the high beam and a 5W bulb for the standing lamp

### Bi-Xenon projection system

The halogen projection system can be replaced by a bi-Xenon projection system (optional equipment) which performs the high beam function as well as the low beam. To differentiate it visually from the halogen version, a transparent area above the low beam lamp is illuminated and creates interesting light effects when viewed from the side. The equipment package of the bi-Xenon headlamps includes a headlamp cleaning system, an electronic headlamp range adjustment system and cornering fog lamps.

### Cornering fog lamps

By widening the light scatter of the front fog lamp, the cornering lamps provide significantly improved illumination of the road into which the vehicle is turning. The left or right front fog lamp is activated under the following conditions:

- Driving lamps switched on
- Vehicle speed below 25 mph
- An appropriate steering angle or turn signal activated

The "cornering fog lamps" function is not available in conjunction with the AMG sport package or SLK55.



P82.10-3505-00

*Headlamps*

## Interior design

The interior has been totally redesigned compared to the predecessor model series:

- A newly developed display and control concept with central display and multifunction steering wheel
- A sporty instrument cluster in the form of cylindrical tubes inclined towards the driver
- A prominent full-length center console

- Newly developed sports seats with integral head restraints and magnesium frames
- A new design concept with silver controls and trim strips on a black background

The "designo" equipment line is also available for the interior appointments.

### SLK 55 AMG

- Nappa leather equipment
- AMG ergonomic sport steering wheel with steering wheel shift buttons
- AMG door sill moldings
- AMG sports seats with cross-piping design and AMG badge on the backrest
- Nappa leather armrest between the seats
- AMG selector lever
- Door linings (center door panel, armrest and door closing handle in Nappa leather)



*Interior compartment (SLK350)*

## Interior

### Instrument cluster

The instrument cluster of the SLK contains the speedometer (left) and the tachometer (right) in the form of dial-type gauges each enclosed by a cylindrical tube. The elliptical ends of the tubes facing the driver are tilted towards each other and are finished in a silver finish like the external surfaces. On the side of the left-hand tube are three adjusting buttons. Two of the buttons (+, -) are used to regulate the dimming of the instrument illumination. The third button (R) is the reset button.

The speedometer contains various warning lamps as well as an analog clock, and the tachometer incorporates an analog fuel gauge. The faces of the two dials are background-lit in daylight. The illumination brightness is automatically adjusted to suit the light conditions inside the car by means of a phototransistor, but can also be regulated manually with the aid of the adjusting buttons.

Between the dial gauges are two LCDs, one on top of the other, containing information for the driver (including mileage, outside temperature and transmission mode).

### SLK 55 AMG

The AMG instrument cluster differs in:

- 320 km/h scale
- Red needles
- Anthracite-colored tubes
- Dial faces edged in silver
- AMG and V8 logos in the tachometer

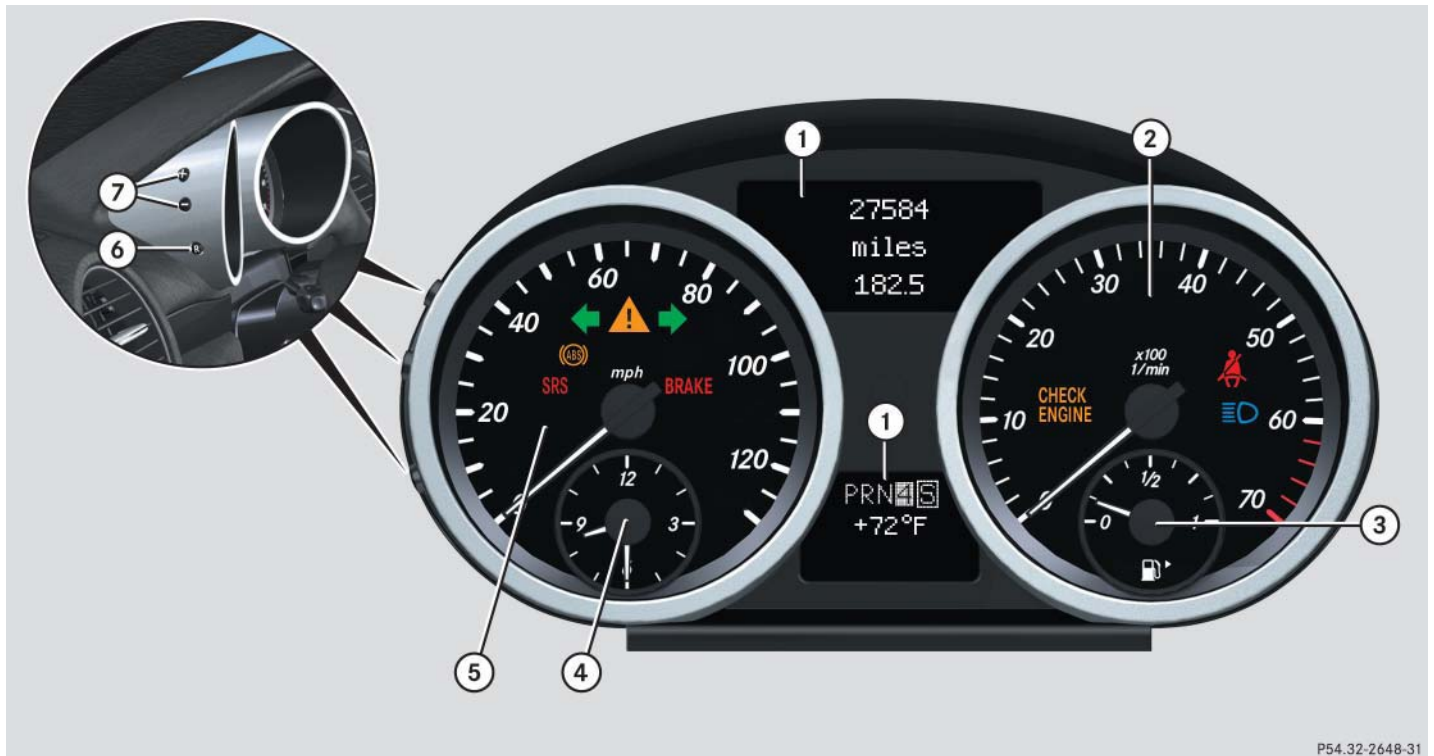

P54.32-2648-31

#### Instrument cluster

- |                          |                                 |
|--------------------------|---------------------------------|
| 1) Multifunction display | 5) Speedometer                  |
| 2) Tachometer            | 6) Reset button                 |
| 3) Fuel gauge            | 7) Knobs for instrument cluster |
| 4) Clock                 |                                 |



### Center console

One major distinguishing feature compared with the predecessor model series is that the top section of the center console is integrated into the dashboard. At its top end it frames a semi oval black grille for indirect ventilation of the interior compartment (vehicles with automatic climate control only). The cockpit ventilation nozzle at the top supplies fresh air to the head area. The grille conceals two adjustable center air outlets with silver-colored slats which are flanked on both sides by prominent ventilation pipes.

Below the center air outlets, the following are arranged on the center console from top to bottom:

- Cup holder
  - Radio/COMAND
  - Switch panel
  - Climate control/automatic climate control module
  - Ashtray with cigarette lighter
  - Storage compartment
  - Transmission selector lever
  - Adjustment switches (including outside mirrors and retractable roof)
- Hand brake lever
  - Armrest with storage compartment (if the car is equipped with a telephone, there is an additional slot for housing the portable CTEL.)
  - Another storage compartment on the rear wall of the interior compartment (the cover is hinged at the bottom and opens forwards.)
  - Two tweeters (optional equipment)



*Dashboard*

## Interior

### Door panels

The forward part of the door panel is characterized by a visual continuation of the top of the dashboard. In this area are the door opener at the top and two speakers underneath (mid-range and woofer). The third speaker (tweeter) is mounted on the inside of the mirror triangle.

A generously sized armrest is installed in the middle of the door panel. Immediately forward of the armrest is the massive magnesium closing/grab handle. On the front end of this are the control buttons for the power windows.

### SLK 55 AMG

On the door lining of the SLK 55 AMG the following elements are covered with Nappa leather:

- Center door panel
- Armrest
- Door closing handle

### Glove compartment

Although a front passenger air bag is fitted, the SLK still has room for a large glove compartment with a capacity of 6.3 liters. The glove compartment is locked and unlocked via the central locking.

The illuminated glove compartment houses a pen and coin holder in the lid as well as a CD changer (optional equipment).



*Glove compartment*

### Deluxe seats

The newly developed sports seats of the SLK differ from those of the predecessor model series in both their external shape and their technical design.

The upper seat belt guide point is anchored in the area of the rear/side wall joint. A loop guides the belts and ensures that they are easily reachable in the retracted position.

Other visual features are the silver-painted, all-round magnesium frame between the backrest cushion and the seat back and rubber bellows concealing the head restraint opening. The long-distance comfort and lateral support of the sports seats have been significantly improved.

The standard equipment of the seats includes:

- Manual seat adjustment (longitudinal position with automatic adjustment of the seat cushion inclination, backrest adjustment (continuous), seat height and head restraint height)
- Fold forward driver seat backrest
- Coat hanger hook on the rear of the backrest
- Head/thorax air bag (in the outboard side of the backrest)
- Static lumbar support
- Leather

Optional equipment available for the seats includes:

- Heated seats (standard for SLK55 AMG)
- Electric seat adjustment with memory function (standard for SLK55 AMG)
- Heated seats with AIRSCARF neck level heating (package)

A new feature of the SLK is the fully electronic seat adjustment with memory function (optional equipment). The operating switches are located on the outside of the seat cushion. The memory buttons can be used to save the current seat position and there are three memory slots available for each of the two electronic keys.



P91.10-2666-00

*Deluxe seat*

## Interior

A head/thorax air bag with gas generator is attached to the outboard edge of each of the silver-colored magnesium backrest frames.

### SLK 55 AMG

The AMG sports seats have the AMG-specific cross-piping design and are covered with Nappa leather. They have more prominently contoured side wings and an AMG badge in the backrest (heated seats as standard).

With the equipment variants "black", "black/accent red" and "black/ash leather" the head restraints and the side wings are black.

These three variants also feature anthracite-colored Alcantara inserts at shoulder level providing additional lateral support.



*Head/thorax air bag*

## Inside rearview mirror

As part of the interior equipment package, two reading lamps (optional equipment) and one ambient lamp (optional package on SLK350, standard on SLK55 AMG) are integrated into the mirror housing. The mirror base also accommodates the GPS antenna and the light/rain sensor.

## Interior lighting

The lighting functions have been redesigned, as has the electronic control of the lights in the interior compartment. With regard to the night design, the orientation lighting functions in particular have been expanded. An ambient lamp (interior ambiance light package) in the inside rearview mirror helps the driver and front passenger find the controls when driving at night. The intensity of the ambient light is detected by a light sensor located in the mirror base and evaluated by the control module in the overhead control panel.

## Overhead control panel

The overhead control panel houses the electronic control and power supply systems for several major components.

These include:

- Interior lights and vanity mirror illumination
- Illumination of the switch symbols
- Light/rain sensor

The following are located in the housing of the overhead control panel:

- Switches for the interior lights
- Tele Aid emergency call system button
- Three buttons for the garage door opener (optional equipment)
- Up to three microphones for emergency call, hands-free system

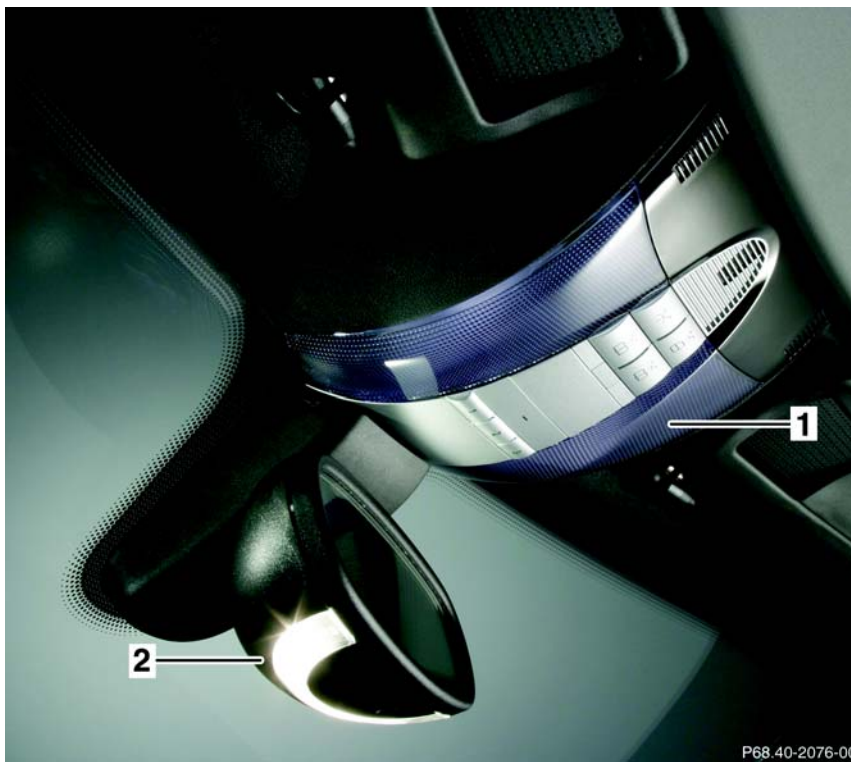

P68.40-2076-00

### *Inside rearview mirror / overhead control panel*

- 1 *Overhead control panel*
- 2 *Inside rearview mirror with interior illumination*

## Interior

### Trunk

As in the predecessor model, the trunk capacity is dependent on the stowage options for the retractable roof.

The new pivot action of the individual roof components has made it possible to fold the "rear window" and "front roof" components on top of each other. This increases the capacity of the lower part of the trunk, which can be used for luggage. The storage capacity is 6.5 cu. ft.

The collapsible spare tire is accessed by swinging up a flap in the trunk floor.

Instead of a roller blind, the trunk is fitted with a fixed luggage cover which pivots in the longitudinal direction. This ensures that the luggage cannot collide with the roof components as they fold into the trunk.

The retractable roof can only be opened when the luggage cover is swung back and locked in place. With the roof closed, the luggage cover can be swung forward in a single action to facilitate the unloading of the trunk. In this way, the entire trunk capacity of 9.8 cu. ft. can be utilized.



P68.00-3564-00

### *Trunk with luggage cover*

1 Luggage cover pivot device

## Engine 113 - Engine data

		SLK 55 AMG
Engine model designation		113.989
Engine designation		M 113
Engine configuration/no. of cylinders		V8
Displacement	cm <sup>3</sup>	5 439
Bore	mm	97.0
Stroke	mm	92.0
Cylinder angle		90°
Acceleration 0 to 100 km/h	secs.	4.9 <sup>1,3</sup>
Maximum speed	km/h	250 <sup>1,2</sup>

<sup>1</sup> With automatic transmission

<sup>2</sup> Electronically governed

<sup>3</sup> Stated rates of acceleration are based upon manufacturer's track results and may vary depending upon model, environmental and road surface conditions, driving style, elevation and vehicle load.

# Engine 113 - Engine data

M 113		
Rated output	kW at rpm	265 5 750
Rated torque	Nm at rpm	510 4 000
Compression ratio	$\epsilon$	11.0

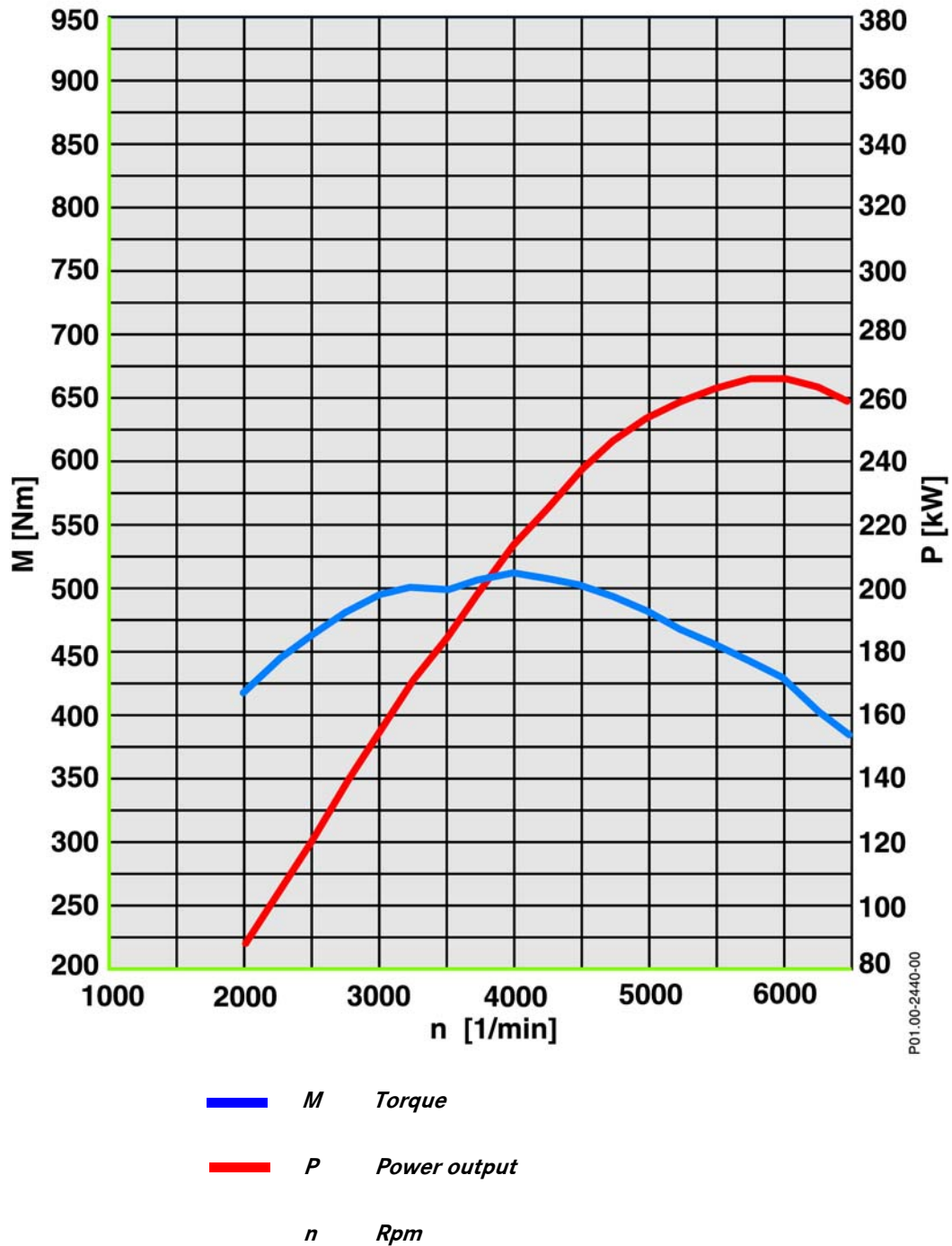



## Engine 113 - Technical highlights

### SLK 55 AMG

The SLK 55 AMG offered by Mercedes-AMG is the only vehicle in this class available with an 8-cylinder engine. The AMG 5.5 l naturally aspirated engine in the new SLK develops 265 kW and 510 Nm together with the AMG sports exhaust (which is perfectly tuned for the 8-cylinder engine).

The engine's technical characteristics are:

- Two-stage variable-length intake manifold
- Near-engine mounted catalytic converter for lower emissions
- Specially tuned engine oil cooler in the right wheelhouse
- Redesigned engine cover
- Engine control module installed in the vehicle (in an AMG-specific module box)
- Lower fuel consumption due to optimized combustion, reduced friction and consistent lightweight construction



P01.00-2458-00

*Engine 113*

### AMG exhaust system

The AMG sports exhaust system in the SLK 55 AMG satisfies the US emissions limits and is perfectly tuned in terms of function and sound to the AMG 5.5 l V8 engine. The near-engine mounted bulkhead catalytic converter is coated with palladium/rhodium while the under-floor catalytic converter is platinum/rhodium-plated. The longevity of the exhaust system is provided by the use of stainless steel throughout.

The catalytic converter system incorporates one bulkhead and one underfloor catalytic converter (both made from thin-wall ceramic) in each exhaust stream. Downstream of the separation point of the two catalytic converter systems, the exhaust streams are combined in the center muffler. Further on, the exhaust flow continues in twin pipes to the two rear mufflers.

The AMG sports exhaust system ends in two chrome-plated twin tailpipes bearing the AMG logo.

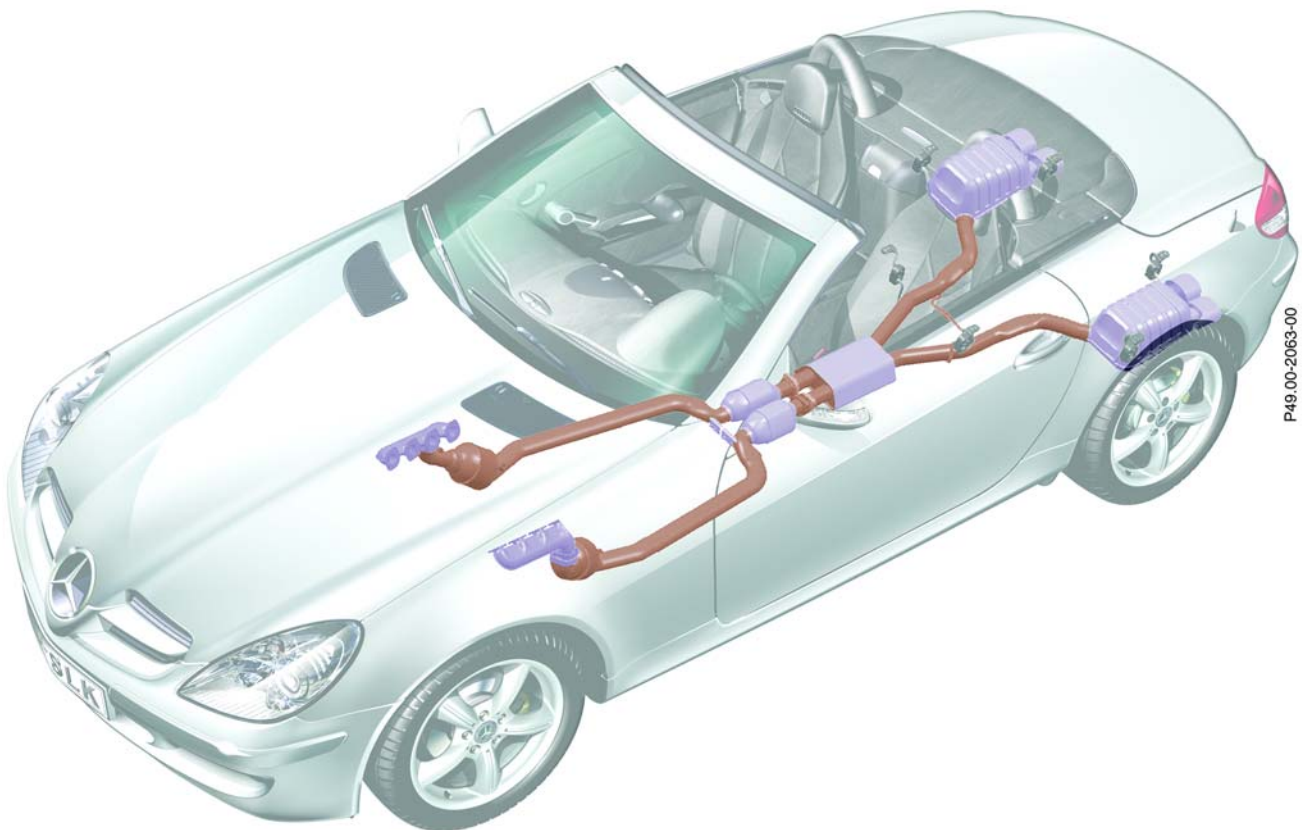

P49.00-2063-00

**Exhaust system**

## Engine 272 - Overview

### New V-6 engine generation 272

#### Engine series

Model 171 SLK350 will be the first vehicle equipped with the new engine 272.

The new six cylinder V-6 engine features variable adjustment of intake and exhaust camshafts.

#### Lightweight construction

As a result of its consistent lightweight construction the weight gain in comparison to its predecessor the M 112 has been slightly reduced.

This is despite the use of a solid four-valve system with four camshafts and camshaft adjustment and the two-level intake module with turbulence flaps in the inlet ports.

#### High power

With a displacement of 3498 CC the new V6 engine delivers 268 hp (200 kW) at 6000 rpm. This yields a volumetric efficiency of 57 kW/78 bhp—a top value in this displacement class. The torque of 350 Nm is available right from 2500 rpm and remains constant up to 5000 rpm.

#### Performance

Acceleration from 0 to 100 km/h:

- 5.5 secs.<sup>1)</sup> (with manual transmission)
- 5.6 secs.<sup>1)</sup> (with automatic transmission)

Maximum speed:

250 km/h (with manual or automatic transmission, electronically governed)

#### Turbulence flaps

Turbulence flaps are fitted in the intake ports. At part-throttle they are extended and increase the turbulence of the intake air in the combustion chambers. At higher revs the turbulence flaps are fully lowered in the induction pipe.

#### Exhaust gas

All the individual measures combine to yield a powerful and free-revving engine with exhaust emissions within US limits:

- Variable camshaft adjustment
- Turbulence flaps in the intake ports
- Internal exhaust recirculation
- Secondary air injection
- Catalytic converters fitted close to engine

#### Internal exhaust gas recirculation

The engine timing can be altered precisely by means of the variable intake and exhaust camshafts. The variable overlap times permit mixing of fresh gas and exhaust gas.

#### Heat management

An intelligent heat management system also helps to reduce fuel consumption. A new kind of electronic map-controlled thermostat, which is active in all the engine's operational modes, guides the flow of coolant into the six-cylinder engine in such a way that the engine oil and coolant always stay at the optimum temperature.

A heating element allows active control of the triple-plate thermostat, causing the coolant to remain short circuited inside the engine during the warm-up period of the engine.

<sup>1)</sup> Stated rates of acceleration are based upon manufacturer's track results and may vary depending upon model, environmental and road surface conditions, driving style, elevation and vehicle load.

## At-a-glance

Target	Measures
Comfort-optimisation through	Balance shaft for smooth engine running
	Greater rigidity in crankcase with full cross-bolting of main bearing cap
	Wider crankshaft bearings
	More rigid engine mounting with larger cross sections
	Reduced moving mass as result of lightweight construction throughout (pistons, con rods)
	Valve cover with integrated camshaft bearing
	Twin cartridge air filter with integrated resonators to reduce intake noise
Consumption-optimisation through	Optimised combustion chamber geometry and valve arrangement
	Reduced friction
	New type of heat management in cooling cycle
	Performance-optimised oil and water pump drive
	Turbulence flaps
	Power steering pump with pressure regulating valve
Exhaust emissions limits fulfilled through	Camshaft adjustment
	Optimised-flow air intake with turbulence flaps
	Optimised combustion chamber geometry and valve arrangement
	Secondary air injection into the exhaust manifold ports
	High-volume catalytic converters close to engine

## Engine 272 - Overview

### Engine data

		<b>M 272.963</b> (SLK 350)	<b>M 112.947</b> (SLK 320)
Engine designation		M 272	M 112
Cylinder-arrangement/angle		V6/90°	V6/90°
Rated power at rpm	kW/hp at rpm	200/268 6000	160/215 5700
Rated torque at rpm	Nm at rpm	350 2400-5000	310 3000-4600
Max. mean pressure	bar	12.6	12.38
Specific power	kW/l PS/l	57 78	50 68
Specific torque	Nm/l	100	97
Compression	$\epsilon$	10.5:1	10.0:1
Cylinder distance	mm	106	106
Displacement	cm <sup>3</sup>	3498	3199
Bore	mm	92.9	89.9
Stroke	mm	86.0	84.0
Con rod length	mm	148.5	148.5

## Engine 272 - Overview

		<b>M 272.963</b> (SLK 350)	<b>M 112.947</b> (SLK 320)
Main bearing diameter approx.	mm	64	64
Con rod bearing diameter approx.	mm	52	52
Intake/exhaust valve head diameter	mm	39.5/30	36/41
Intake/exhaust valve shaft diameter	mm	6	7
Valve stroke intake and exhaust valves	mm	10	10
Valve angle, intake valve	degrees	16.5	23
Valve angle, exhaust valve	degrees	12.0	12.5
Firing order		1-4-3-6-2-5	1-4-3-6-2-5
Maximum continuous speed	rpm	6300	6000
Weight (approx.)	kg	165	149

# Engine 272 - Overview

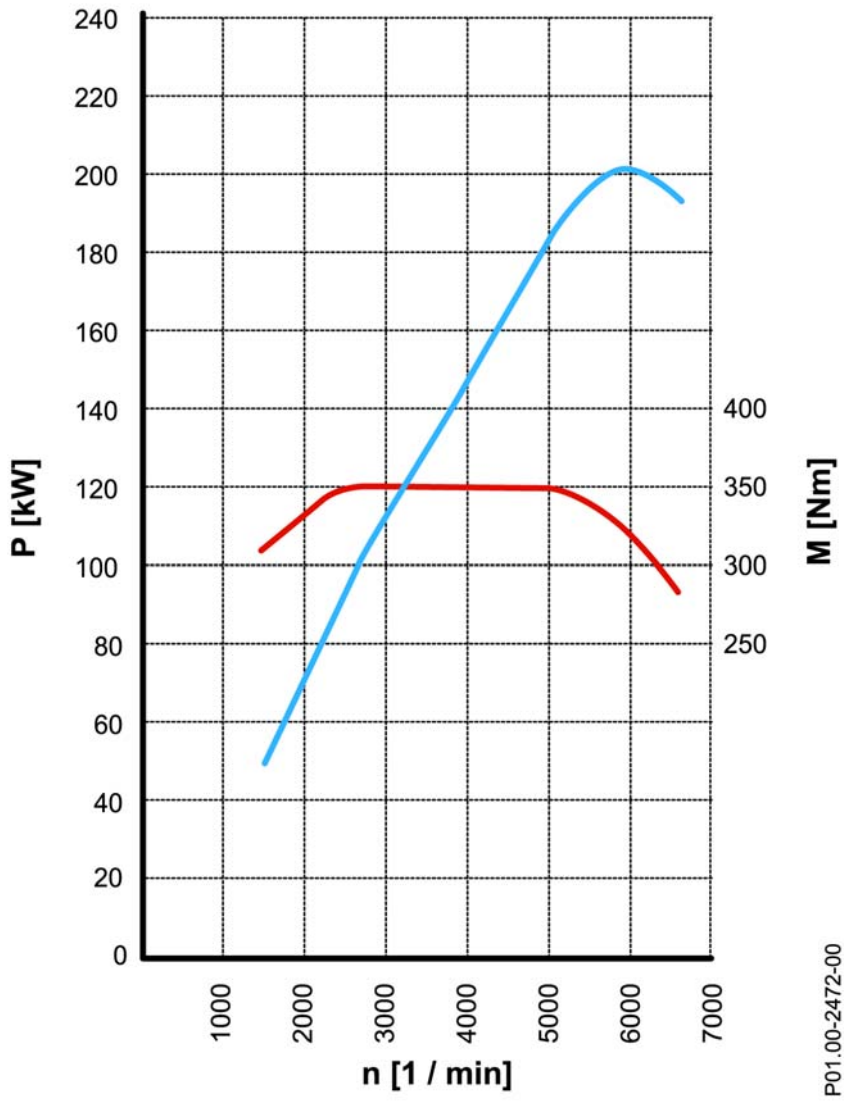

P01.00-2472-00

**M 272.961**

— P Power

— M Torque

n rpm

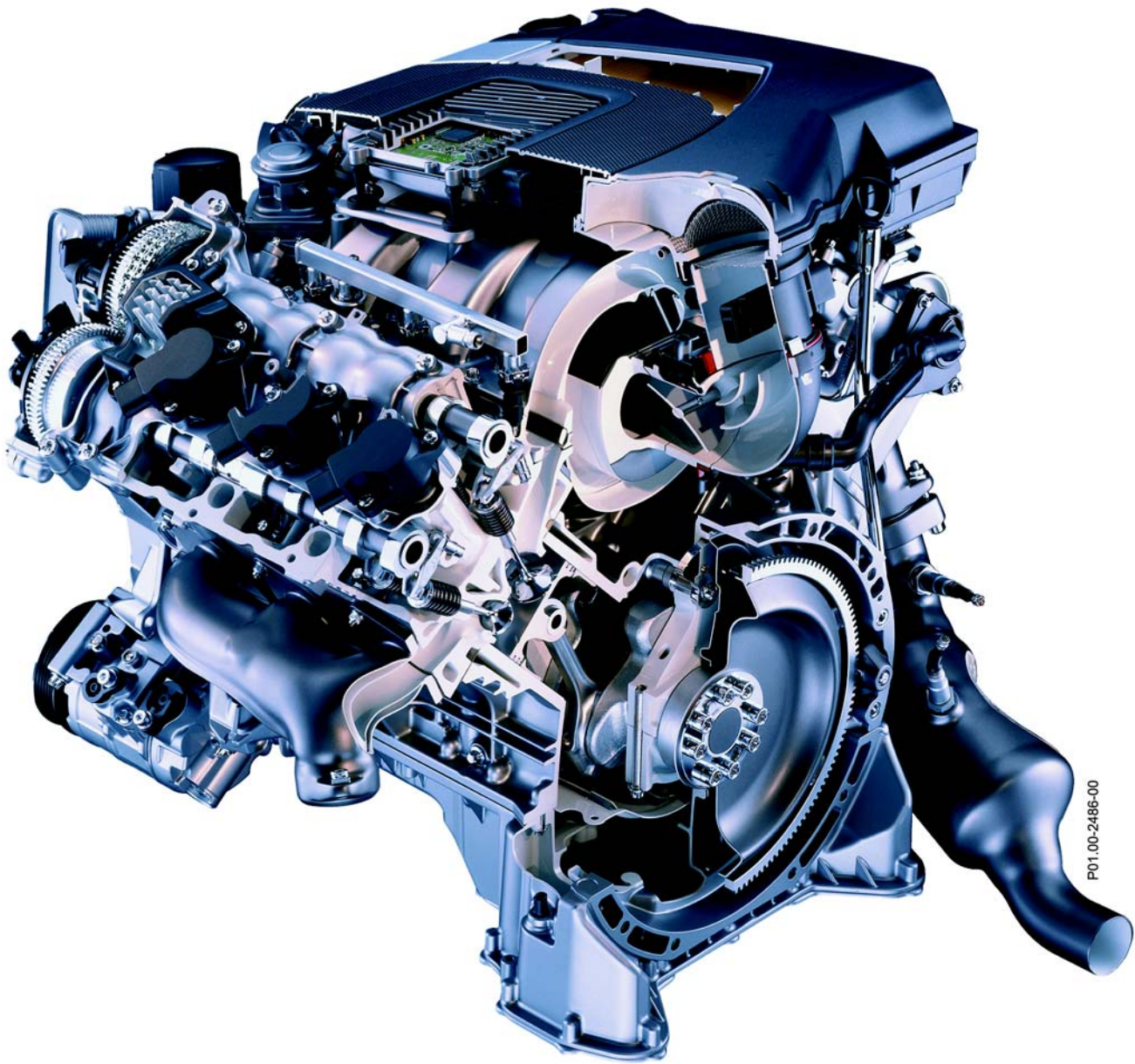

**i** Motorenwerk Stuttgart  
Bad-Cannstatt

The new M 272 is produced in the engine factory in Stuttgart, Bad-Cannstatt.



## Engine 272 - Mechanical

### Cylinder crankcase

As in the M 112, the M 272 has a cylinder angle of 90°. The cylinder distance of 106 mm has also been retained.

The increase in the displacement has been achieved by increasing the stroke to 86.0 mm and the bore diameter to 92.9 mm.

The cylinder crankcase is made from HPDC aluminium. The crankcase is now even more rigid as a result of the cross-bolting of the bearing cap.

### Cylinder liners

The cylinder liners are made from a spray-compacted aluminium-silicon alloy (Silitec) which has already proven its worth in the predecessor, the M 112.

This yields weight savings of roughly 0.5 kg/cylinder in comparison to grey cast iron liners, while offering improved heat flow.

#### **i** HPDC background information

HPDC = High Pressure Die Casting

In this technique the liquid metal is forced at great pressure and at high speed (between 50 and 100 m/sec.) into the casting mold. This requires careful pre planning of the casting process; this is simulated in the computer and takes the flow of the metal and the escape of the gases into consideration to prevent occlusions (local formation of shrinkage cavities, microprocessor).

Advantages of this method:

- high degree of precision
- possibility to cast complex components which, using other production methods, would otherwise have to be assembled from several individual parts
- smooth surfaces and sharp contours
- reduced weight through thin-walled cast parts
- pre and finished casting of bore holes, slits, toothing, recesses and penetrations - plus lettering and numbering
- reduced post-processing costs

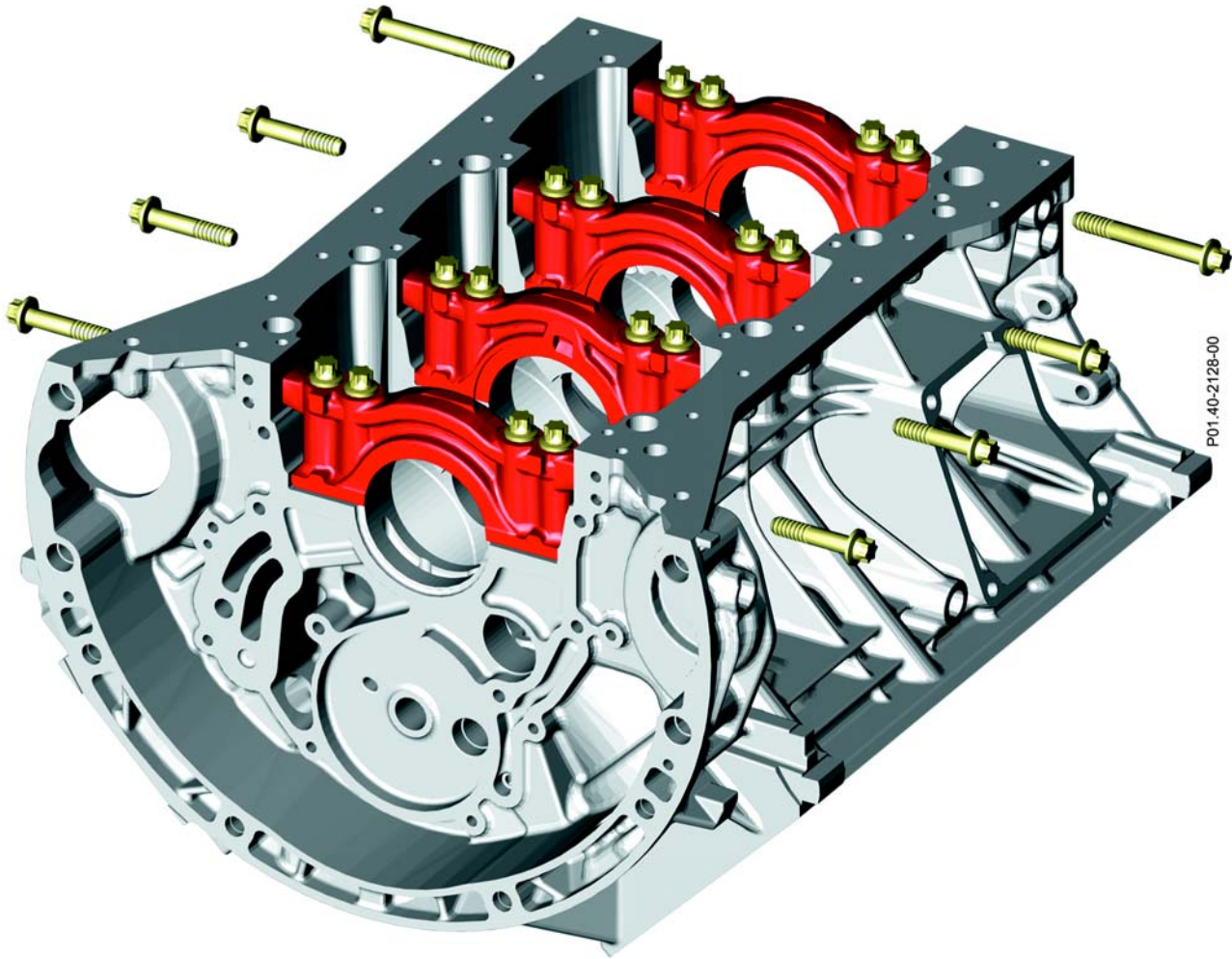

*Cylinder crankcase with cross-bolted main bearing caps*

# Engine 272 - Mechanical

## Oil sump

The M 272 has an oil dipstick and an oil level check switch (S43). There is no oil level sensor.

The top section of the oil sump is made from aluminium. The silicon-sealed bottom section of the sump is made from sheet steel.

**i** **Bottom section of oil sump**

To facilitate pushing the lower section down from the top section, a nut is welded onto the sheet metal sump.

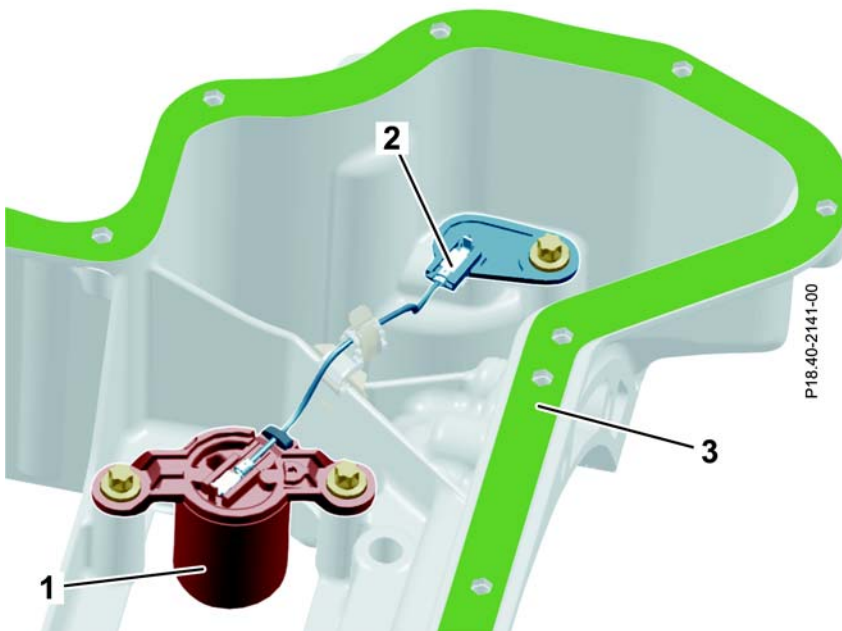
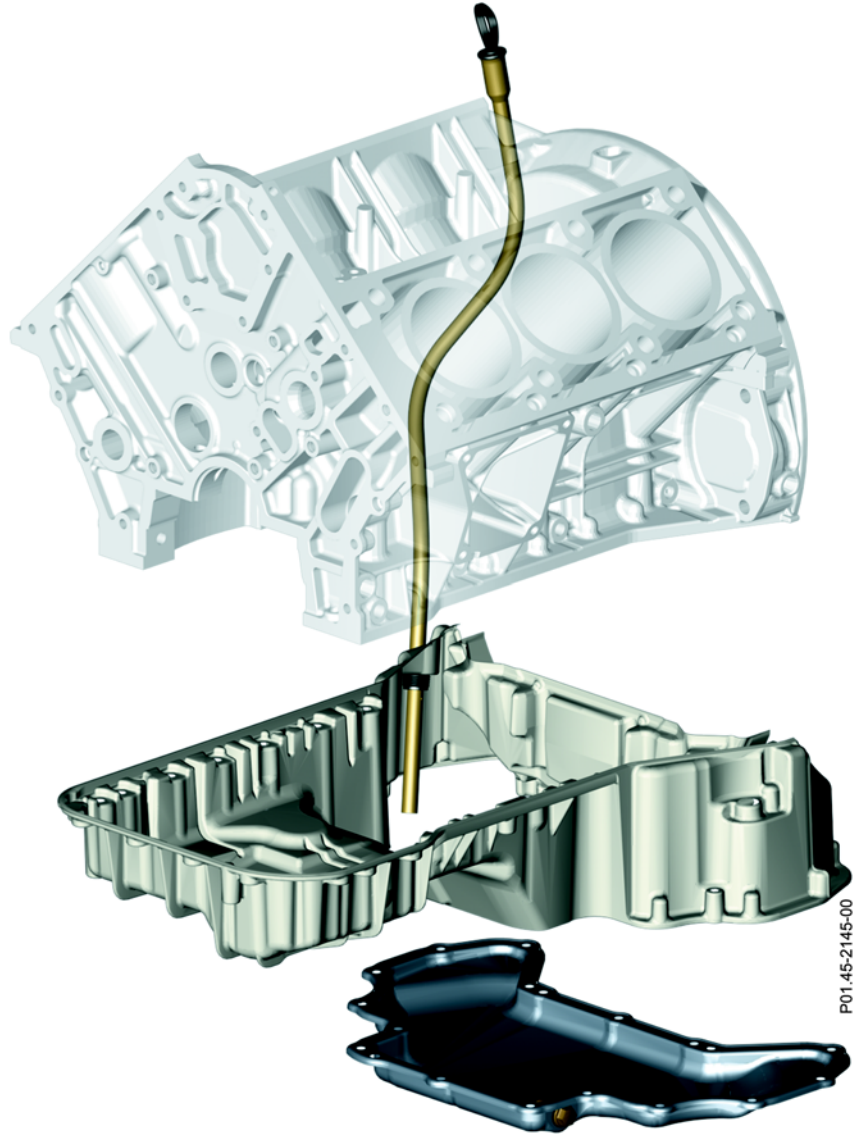

**Switch: oil level check (S43)**

- 1 Float housing
- 2 Plug contact
- 3 Gasket, oil sump lower section

### Oil pump

The lubricating oil is supplied in the M 272 by an internal gear pump. The oil pump is driven by a simplex chain.

The advantages of this type of pump design are:

- smooth running thanks to "soft" tooth engagement
- even pump flow at sufficiently high pressure
- long life due to minimum running wear



*Internal gear pump*

## Crankshaft drive

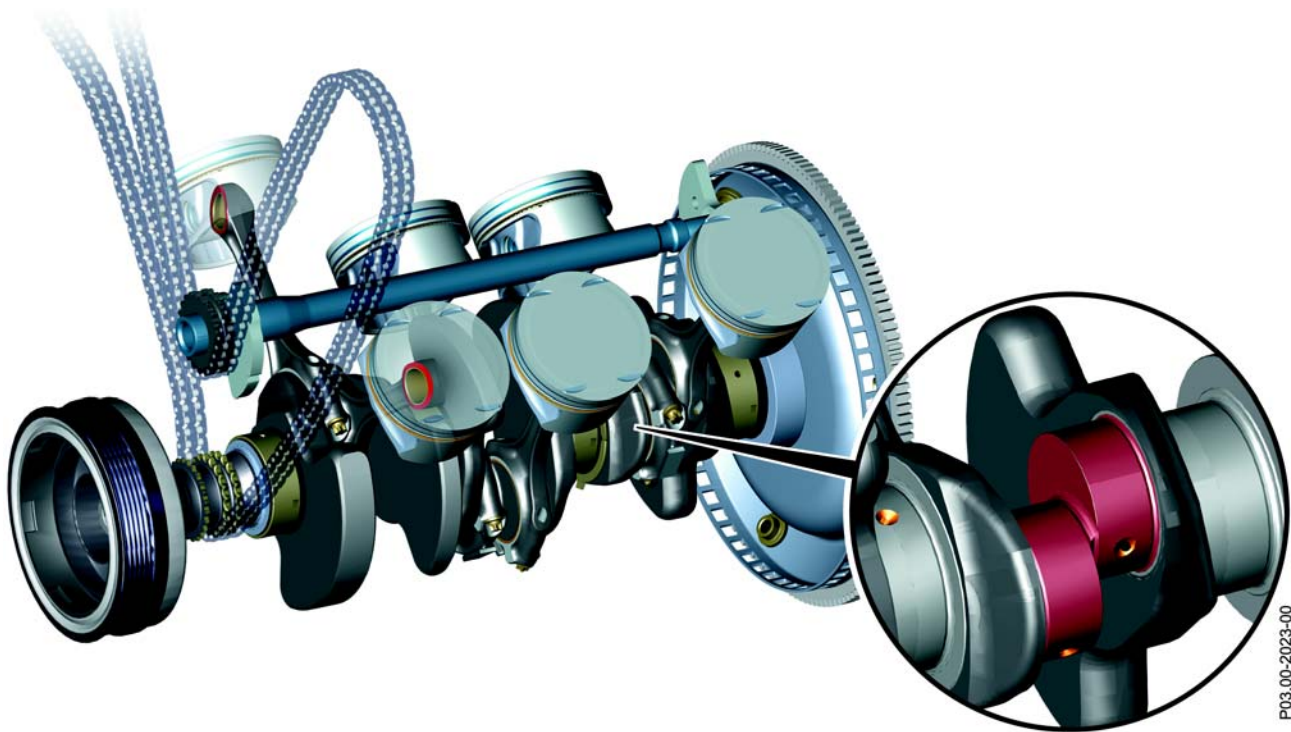

### *Crankshaft drive with balancer shaft*

The moving masses of the crankshaft drive have been reduced. This leads to:

- minimized fuel consumption
- less vibration
- more agile response

### **Crankshaft**

The forged crankshaft has four bearings and four counterweights. The crankshaft bearings have been widened, thereby reducing engine vibration. The connecting rod pins are offset by 30° which permits an even firing angle of 120°.

### **Connecting rod**

The forged steel connecting rods weigh 20 % less, resulting in improved running characteristics. The upper con rod eye is slanted, which reduces weight. It also improves the lubrication of the piston pin.

### **Pistons**

The cast pistons are made from iron-coated aluminium. In conjunction with the valve angle of 28.5 degrees the piston crown creates a combustion chamber with a high compression ratio of 10.5:1. The nitrided steel piston rings are designed for lower friction.

### **Balancer shaft**

A balancer shaft is used between the cylinder banks to balance the free mass forces necessitated by the design of a V6 engine with a 90° cylinder angle. This shaft rotates counter to the crankshaft, but at the same speed as the crankshaft.

## Cylinder head

The cylinder head of the M 272 is produced using a permanent mold aluminium casting technique. The spark plugs are located centrally between the four valves. Directly above them are the coils of the map-controlled direct coil ignition.

The bearings of the camshafts are integrated in the valve covers. If the valve covers are removed during servicing, auxiliary bearing caps are needed. Viewed from the front, the second camshaft bearing serves as the thrust bearing.

The vacuum pump used in some engine versions is driven by the left intake camshaft. The right exhaust camshaft drives the centrifugal oil separator.

The combustion chamber geometry is designed for fast combustion rates, especially at full-throttle. The result is lower knock sensitivity.

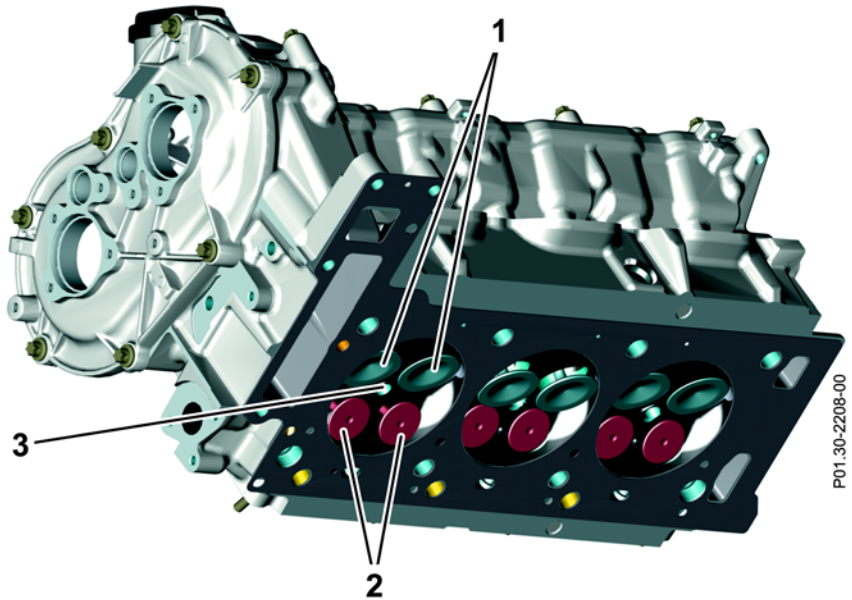

P01.30-2208-00

**Cylinder head M 272 (right)**

1 Intake valves

2 Exhaust valves

3 Spark plug bore

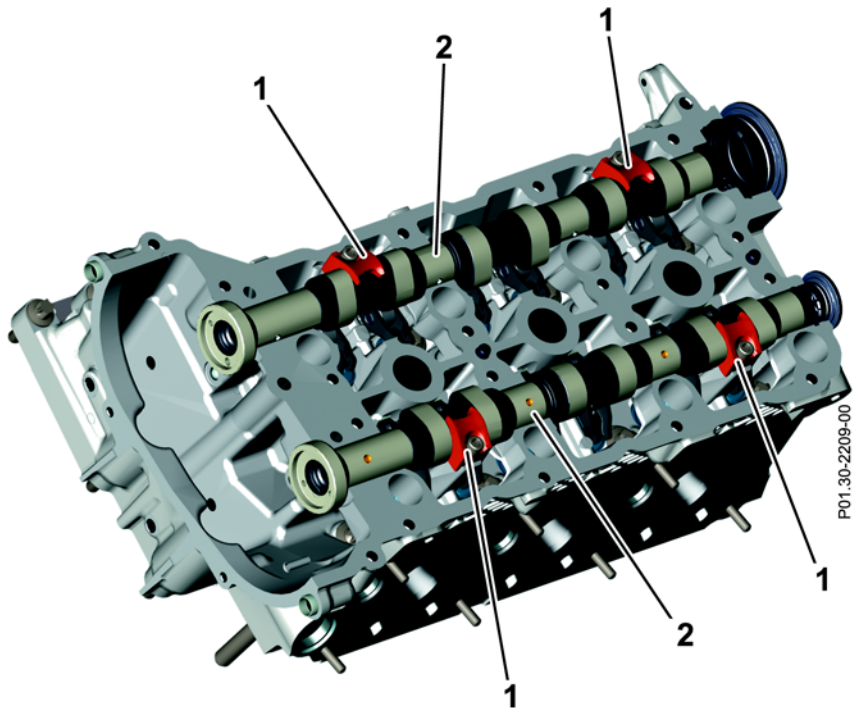

P01.30-2209-00

**Auxiliary bearing cap with valve cover removed (left)**

1 Auxiliary bearing cap

2 Thrust bearing

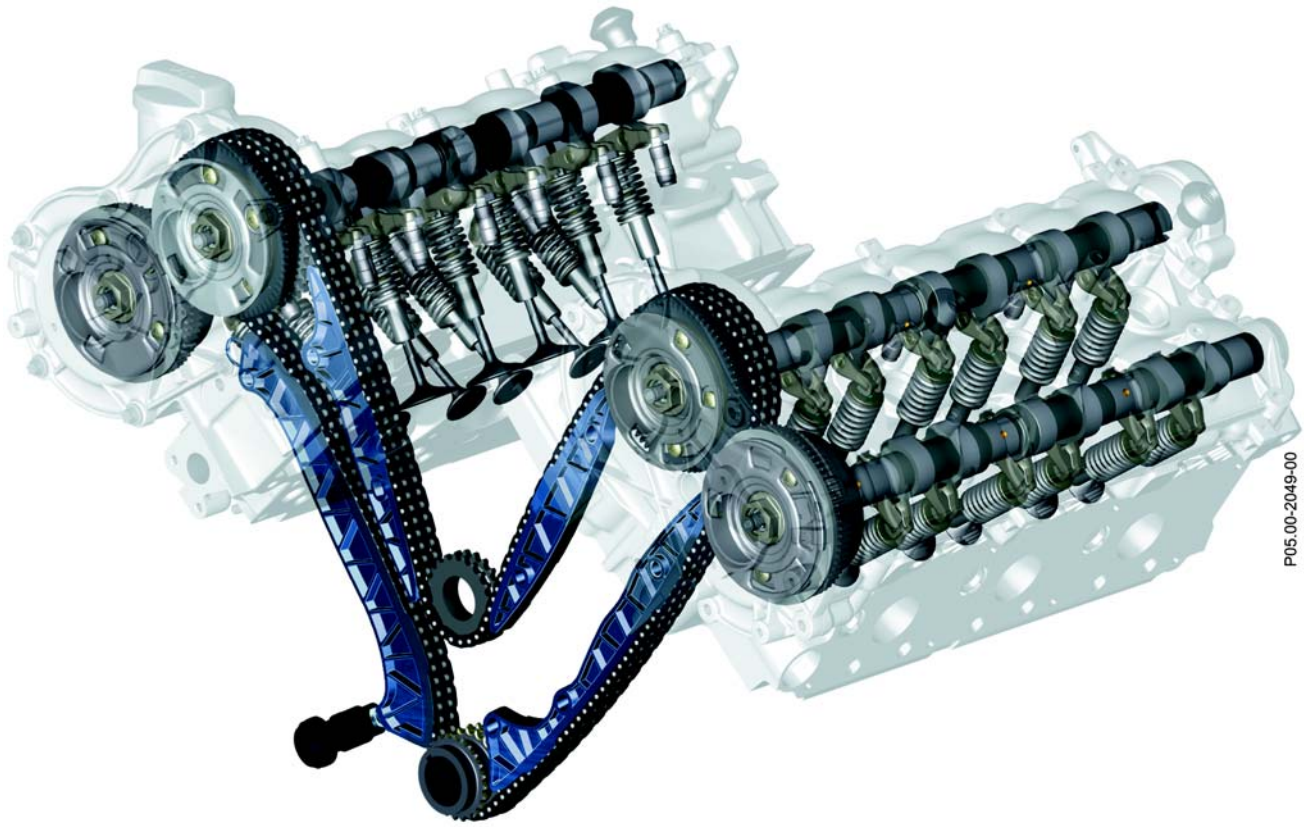

P05.00-2049-00

## Valve train

### General

A double bushing roller chain drives the intake camshafts. The exhaust camshafts are driven directly by the intake camshafts via a spring tensioned spur gear. The chain tensioner is designed as a timing chain tensioner.

The valve train is designed to avoid any free chain run sections. All sections are guided by tensioning and slide rails. This has a positive impact on the dynamism and the noise response of the timing drive.

The M 272 has a low-friction roller cam follower.

### Four valve system

In contrast to the predecessor, the M 112, which had 3 valves per cylinder, the M 272 has 4 valves per cylinder. This arrangement allows the single spark plug to be positioned centrally, yielding optimum combustion.

Exhaust valves made from high-temperature resistant Inconel steel. Both the intake and exhaust valves have a shaft diameter of 6 mm (M 112 has 7 mm). This only restricts the flow in the ports to a minimum extent and, as a result of fewer moving masses, this produces a low-friction and free-revving valve train.

The center position of the valves differs in the various displacement versions and is adapted in line with the individual bore diameter. This means that the intake and exhaust valves can be optimally positioned for each bore diameter.

#### **i** Inconel

Inconel is a material consisting mainly of nickel and chrome plus the alloy components molybdenum, iron and small quantities of aluminium and other elements.

Characteristics: high degree of tensile strength, toughness and resistance to oxidation, corrosion and heat.

### Variable valve timing

The intake and exhaust camshafts can be adjusted continuously by 40 degrees.

The infinitely variable adjustment of the camshafts is carried out by patented, electrohydraulically operated vane adjusters mounted on the front ends of the camshafts, with integrated control valves (similar to the 271).

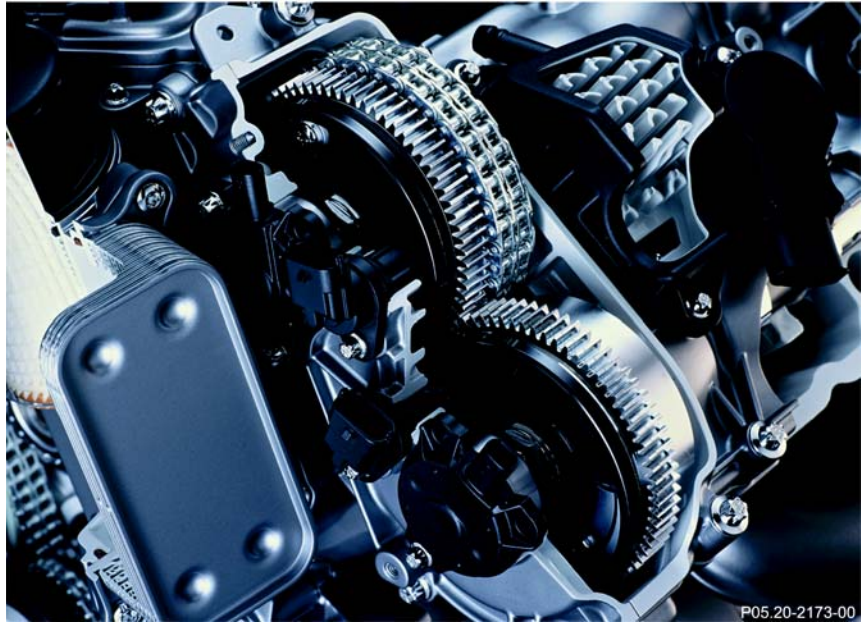

*Camshaft adjuster*

#### **i** Advantages of variable valve timing

Internal exhaust gas recirculation possible:

- less energy lost during charge change in the cylinders
- better exhaust emissions

Good volumetric efficiency:

- Adjustment of valve overlap in line with revs
- Optimised cylinder filling
- Increased power and torque



## Engine 272 - Mechanical

### Tooth backlash compensation

The spur gear toothing of the exhaust camshaft adjuster is gripped between the front gear (1), the grip gear and the rear gear (2) of the main toothing.

The grip force of the spring pushes the spur gears of the exhaust camshaft adjuster away from each other, thereby pressing them, free of backlash, onto the tooth flanks of the spur gear of the intake camshaft adjuster.

The gripped gears help reduce engine noise, above all when idling.

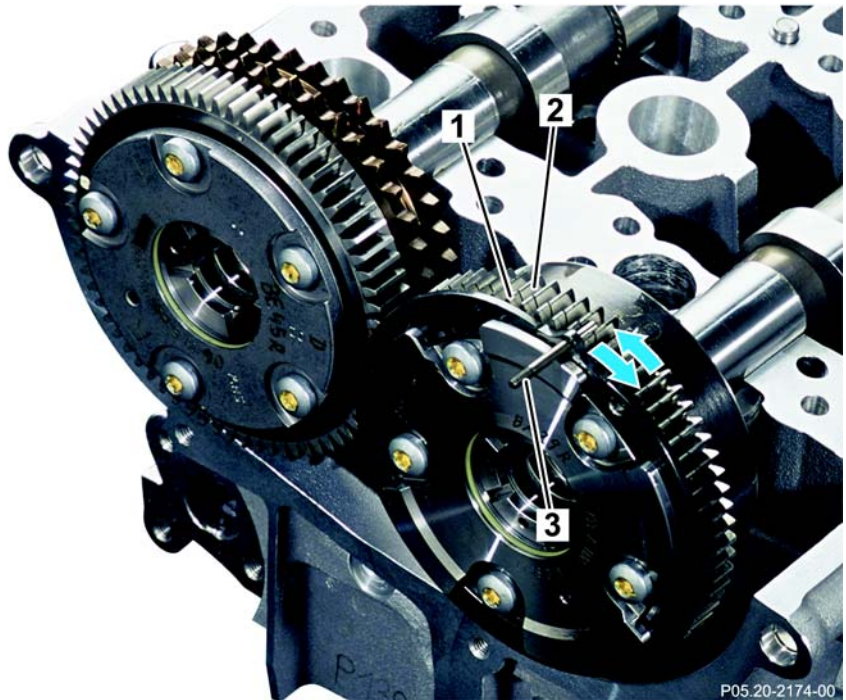

*Tooth backlash compensation*

- 1 Front gear
- 2 Rear gear
- 3 Pin

#### **i** Note WIS repair instructions!

Before removing the exhaust camshaft adjuster, a pin must be inserted in the bore of the support element. Lever and lateral forces **must** be avoided. Otherwise the camshaft adjuster could be damaged.

### Pulse wheels

The pulse wheels are attached to the camshaft adjusters. They are needed to register the position of the camshafts.

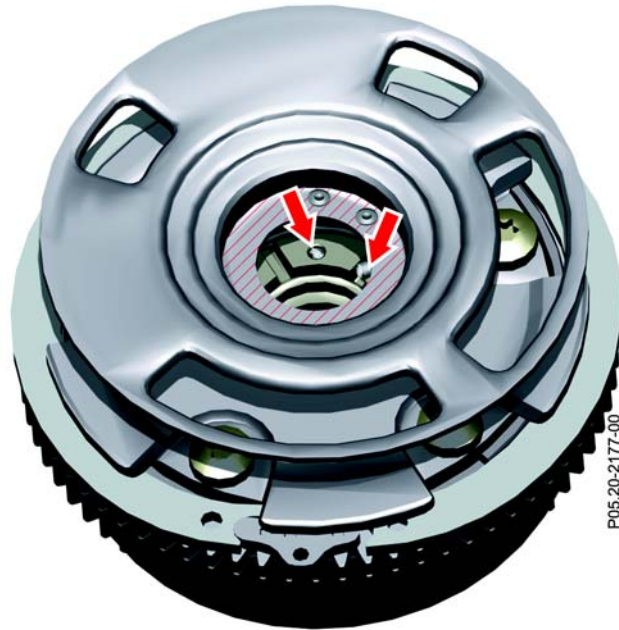

*Used pulse wheel: Shorn pins (arrows) Score marks and flattening (hatching).*

**i** **Note WIS repair instructions!**

Pulse wheels should only ever be fitted once! Otherwise there is a risk of the pins shearing off.

# Engine 272 - Mechanical

## Timing chain tensioner

**i** **Note WIS repair instructions!**

If the assembly sequence of the timing chain tensioner described in the WIS is not observed, this can result in engine damage through torn timing chains.

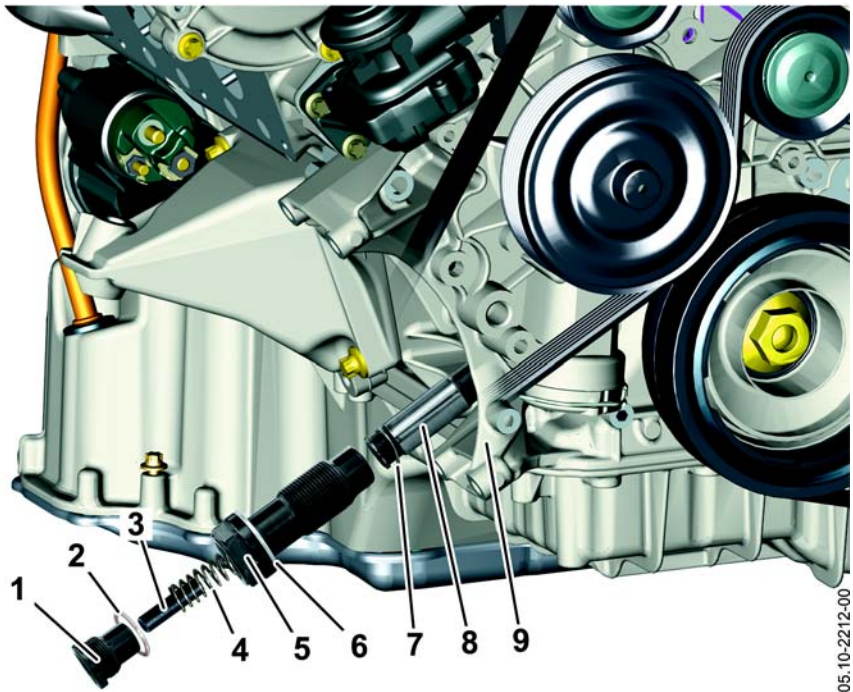

P05.10-2212-00

**Timing chain tensioner  
(exploded view, not the  
assembly sequence!)**

- 1 End piece
- 2 O-ring
- 3 Filler piece

- 4 Compression spring
- 5 Chain tensioner housing
- 6 O-ring
- 7 Locking spring
- 8 Pressure bolt
- 9 Timing cover

## Engine venting

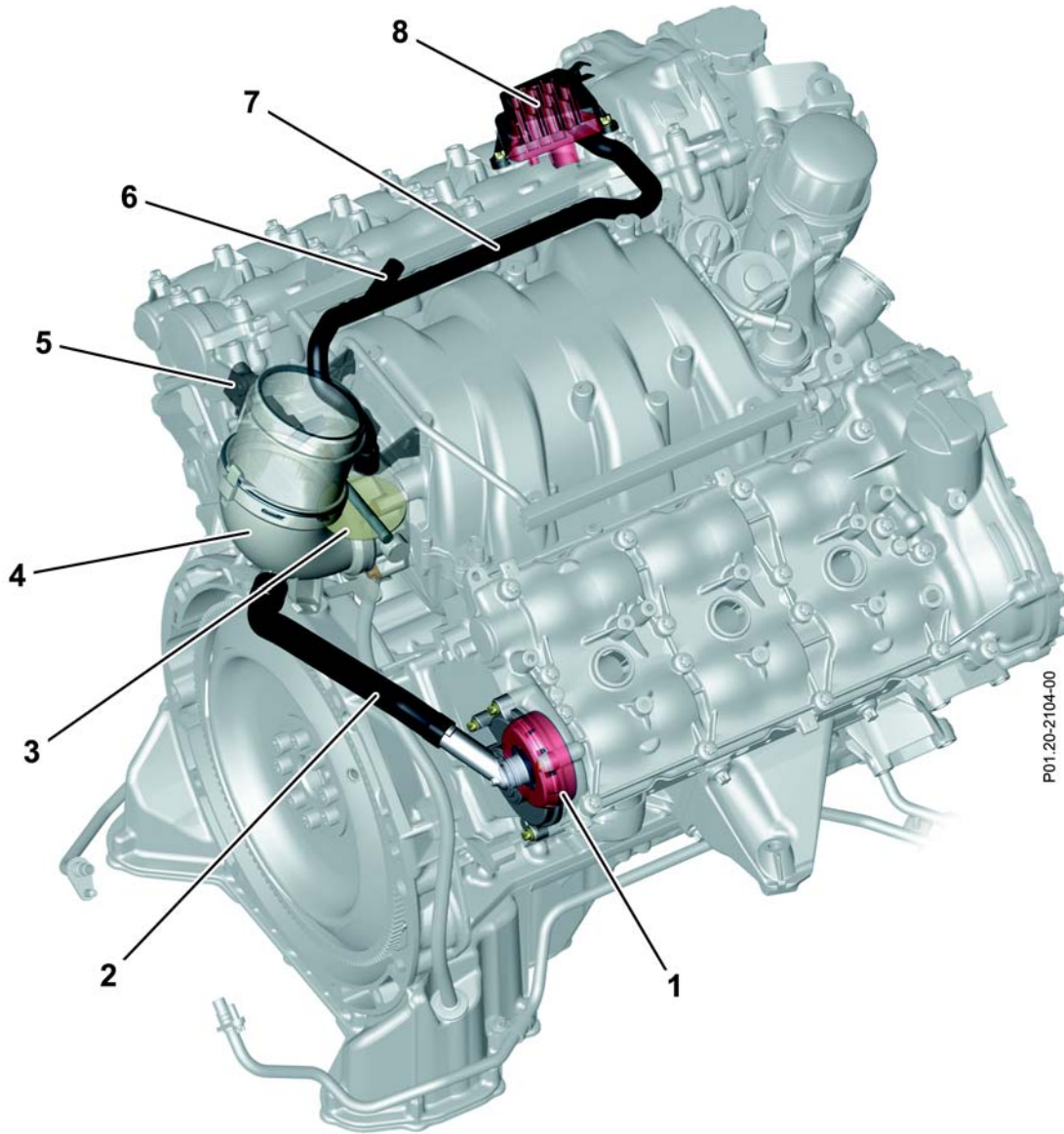

P01.20-2104-00

### **Oil separation**

- 1 Centrifugal oil separator
- 2 Full-throttle vent line

- 3 Throttle valve
- 4 Air guide housing
- 5 Mass airflow meter (MAF)

- 6 Scavenging line connection
- 7 Part-throttle vent line
- 8 Oil separator

The oil separator (8) is responsible for part-throttle venting. The oil vapor contained in the blow-by gas are separated in its labyrinth. The part-throttle vent line (7) leads to the air guide housing (4) behind the throttle valve (3).

At higher load levels the centrifugal oil separator (1) is responsible for the venting.

The full-throttle vent line (2) leads between the throttle valve (3) and the mass airflow meter (5) to the induction pipe (4). The air which has had oil mist removed from it is not measured by the MAF.

## Engine 272 - Mechanical

A centrifugal oil separator is used in the M 272 which is driven by the right exhaust camshaft.

Vapor containing oil mist flows from the crankcase into the centrifuge (5), which rotates at the same speed as the camshaft. This starts the vapor rotating. The oil separates out and drips through the screen filter (4) back into the crankcase. The purified air flows via the full-throttle vent line (2) to the air guide housing.

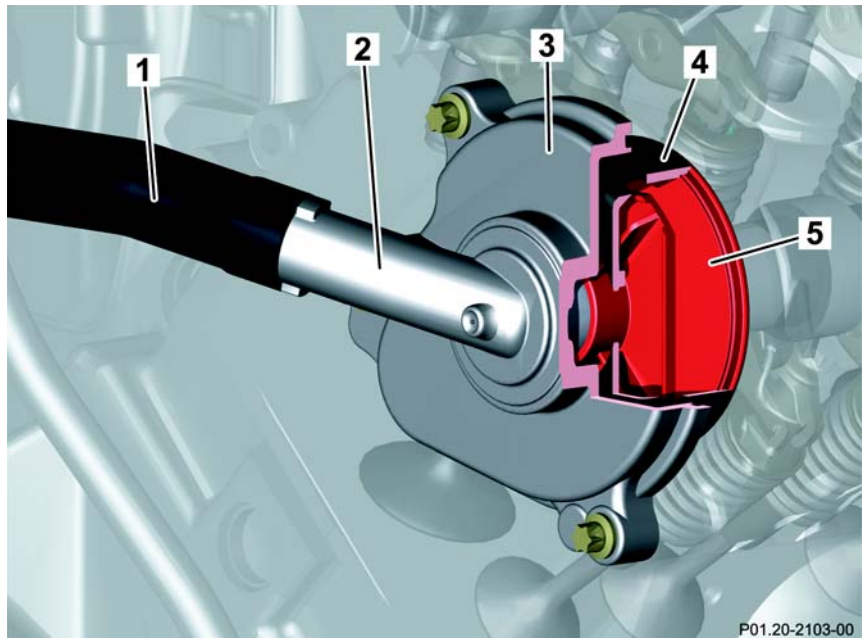

### Ventilation of crankcase

In no load and part load more blowby gas is taken out via the hose from the crankcase than enters from the combustion process. The volume difference flows over the full load hose into the crankcase (fresh air ventilation). The location of the part load and full load ventilation provides for a diagonal flow of air through the motor with fresh air. In full load operation the throttle plate is wide open. Thereby the throttling effect is lost and vacuum decreases.

#### **Centrifugal oil separator**

- 1 Line to induction pipe
- 2 Full-throttle vent line

- 3 Cap
- 4 Screen filter
- 5 Centrifuge

#### **i Ventilation of crankcase**

Ventilation of the crankcase with fresh air has a positive effect on the oil quality: the high throughput of vapor removes more water and fuel from the engine oil.

## Belt drive

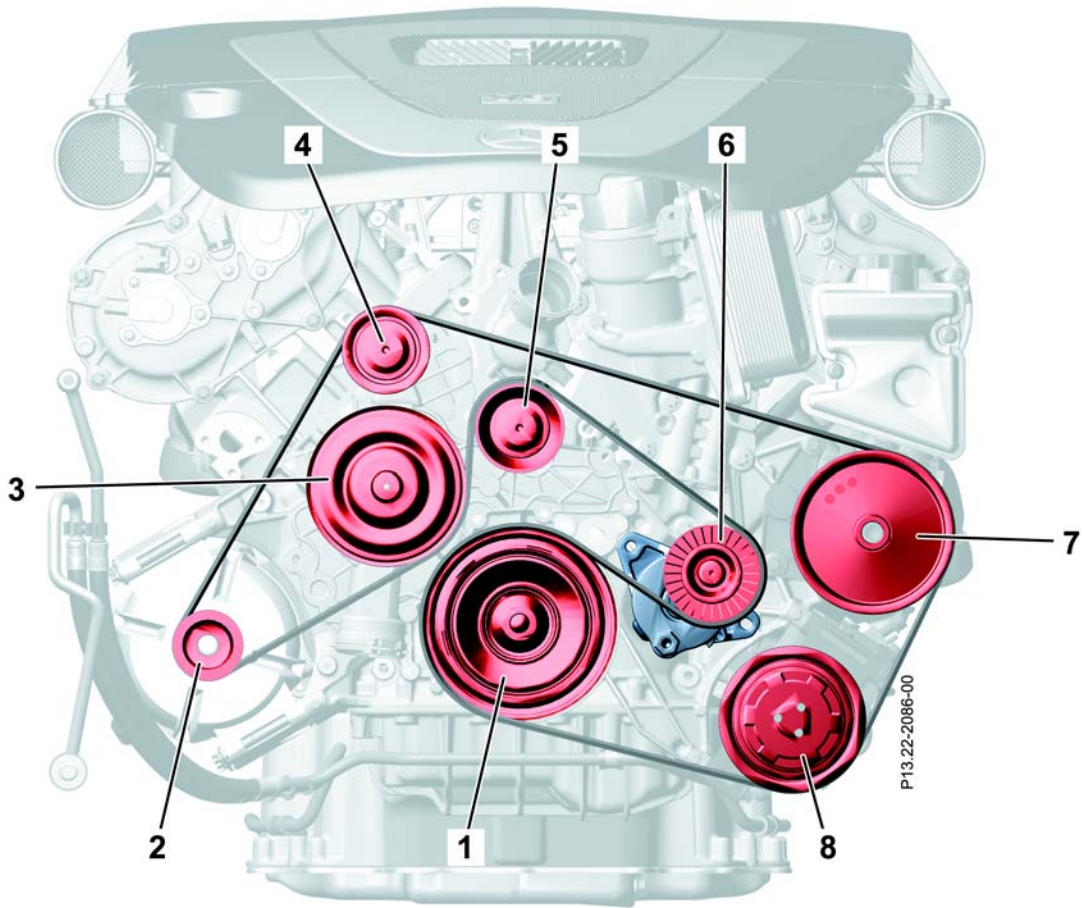

**Belt routing M 272**

Number of ribs: 6

- |   |                           |   |                            |
|---|---------------------------|---|----------------------------|
| 1 | <i>Pulley, crankshaft</i> | 5 | <i>Steering roller</i>     |
| 2 | <i>Generator</i>          | 6 | <i>Idler</i>               |
| 3 | <i>Coolant pump</i>       | 7 | <i>Power steering pump</i> |
| 4 | <i>Steering roller</i>    | 8 | <i>A/C compressor</i>      |

# Engine 272 - Combustion

## Intake manifold

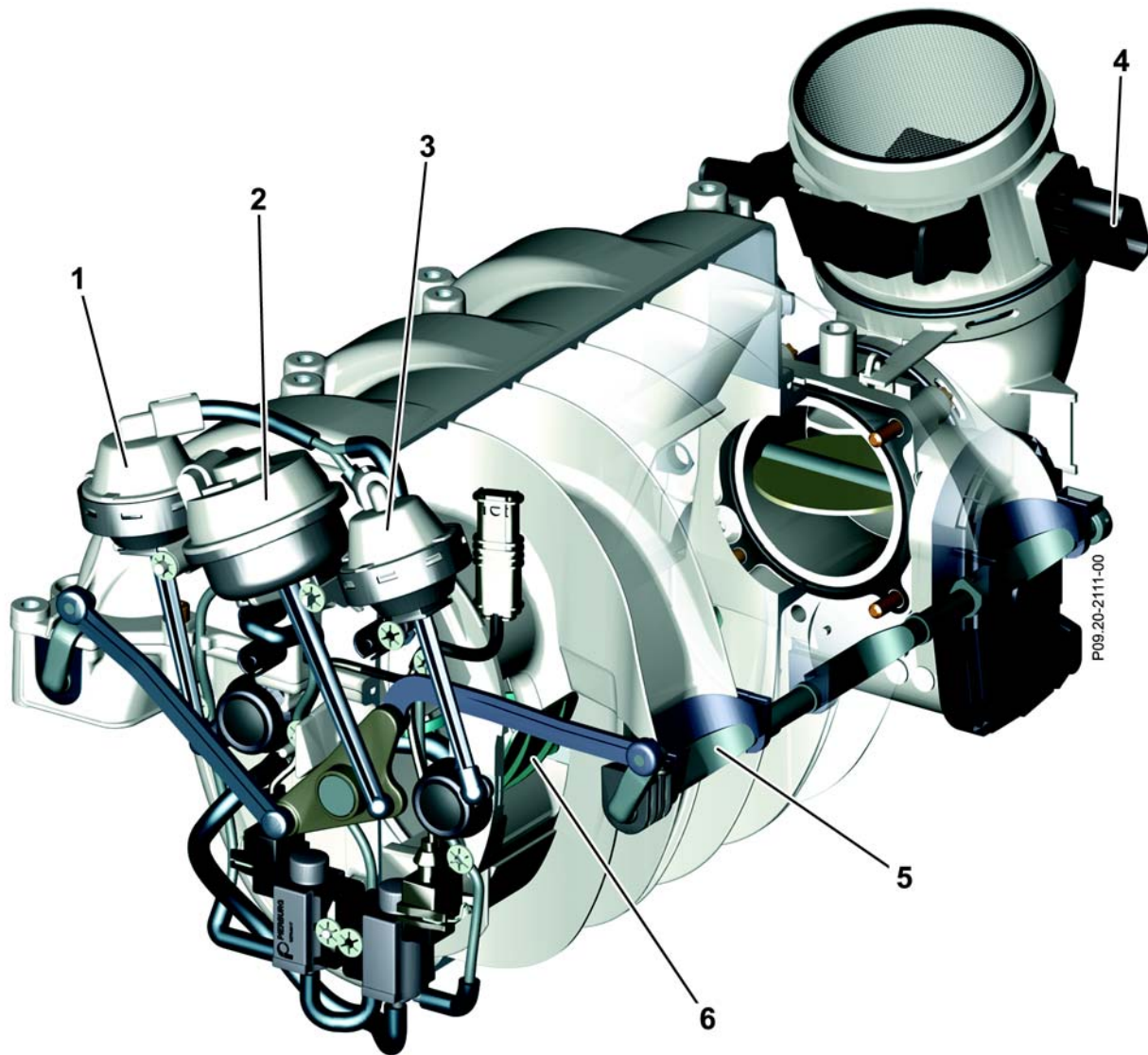

**Intake manifold**

1 Diaphragm unit routing flaps, right cylinder bank

2 Diaphragm unit turbulence flaps  
 3 Diaphragm unit, routing flaps, left cylinder bank

4 Mass airflow meter  
 5 Turbulence flaps  
 6 Routing flaps

The housing of the intake manifold is made from magnesium die cast parts which are joined and bonded using a tongue and groove system. In contrast to plastic, magnesium has the advantage of greater rigidity and dimensional stability which provides improved sealing in the port.

The intake pipes to the air filter are made from sound-absorbent nylon and, in contrast to the smooth surface plastic used up to now, has the advantage of making the material sound-absorbent, thereby significantly reducing the intake noise level.

## Mass airflow meter (MAF)

Like the entire intake manifold, the housing of the enhanced mass airflow meter (MAF 62) has been optimized in terms of flow. The housing of the mass airflow meter has a modified grating with low air resistance.

## Routing flaps

The routing flaps inside the intake manifold vary the length of the intake channels. The routing flaps are opened or closed depending on the load.

At low revs the routing flaps are closed which increases the length of the intake channels. The length is calculated so that the pressure waves in the induction pipe move the combustion air towards the intake valve during the intake stroke. This increases the cylinder charge, in turn optimizing the torque band and lowering the fuel consumption and the emissions.

The routing flaps open from around 3500 rpm allowing the air to flow directly into the combustion chambers. The length of the intake channels is calculated to ensure a "supercharging" effect, even at high revs. This yields high performance at high revs.

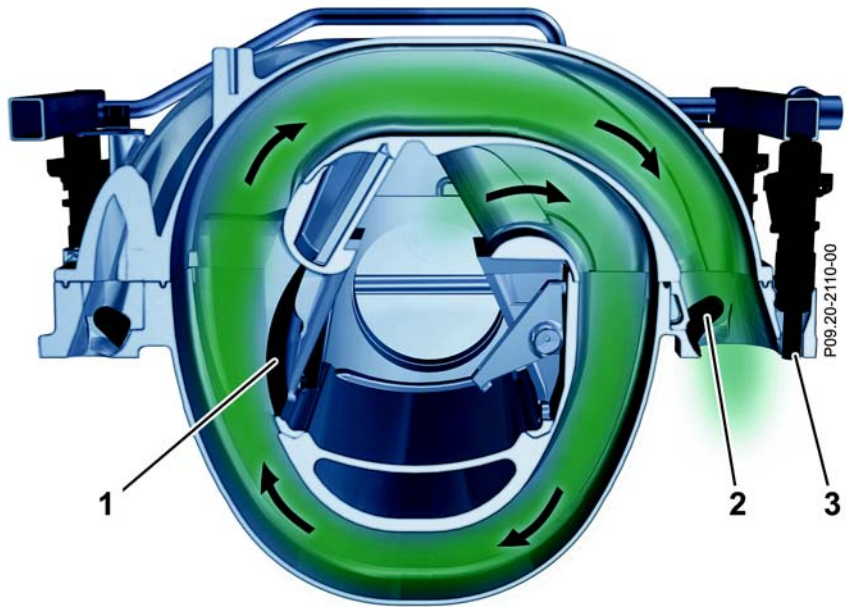

***Routing flaps closed, long intake channels***

- 1 Routing flap
- 2 Turbulence flap
- 3 Injection valve



***Routing flaps open, short intake channels***



Turbulence flaps

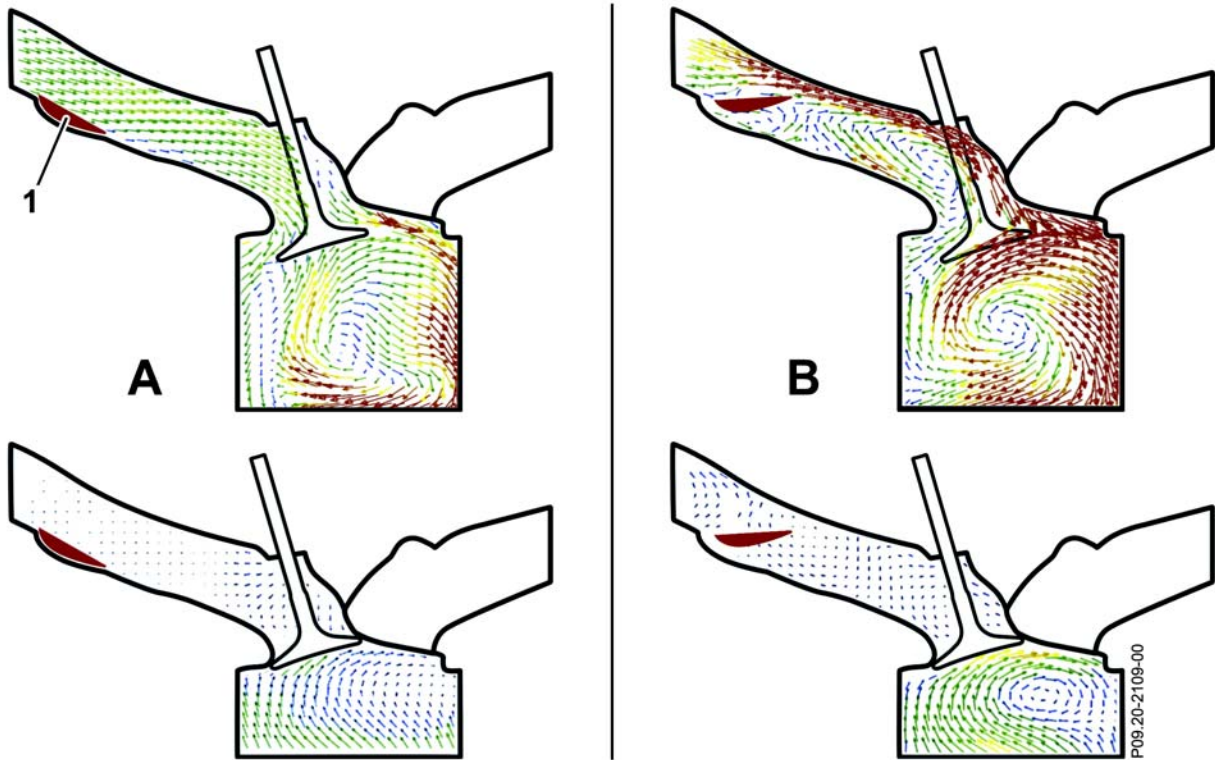

**Charge movements**

1 Turbulence flap

A Turbulence flaps lowered at higher engine load

B Turbulence flaps pivoted out at part-throttle

**Turbulence flaps**

Electropneumatically activated turbulence flaps are installed at the end of each intake port. The turbulence flaps have two positions: lowered or pivoted out

When pivoted out at part-throttle, the turbulence flaps increase the flow speed of the incoming air. The resulting turbulence of the fuel-air mixture in the combustion chamber yields a more even distribution of the mixture and therefore better and faster combustion.

At part-throttle, when the mixture is leaner due to the exhaust gas recirculation, the increased combustion speed helps provide lower fuel consumption.

At higher revs the turbulence flaps are fully lowered in the induction pipe; the intake process is unaffected.

## **i** Charge movement

There are two different charge movements in the cylinder – swirl and turbulence. The swirl mirrors the action of the cylinder axle whereas the turbulence motion is perpendicular to this. The upwards movement of the piston converts the turbulence movement into self-amplifying, complex turbulence. This leads to good ignition and burn-through conditions in the mixture.

The results are:

- good ignition of the mixture made leaner by the internal EGR,
- faster and more complete combustion
- lower fuel consumption
- smoother running.

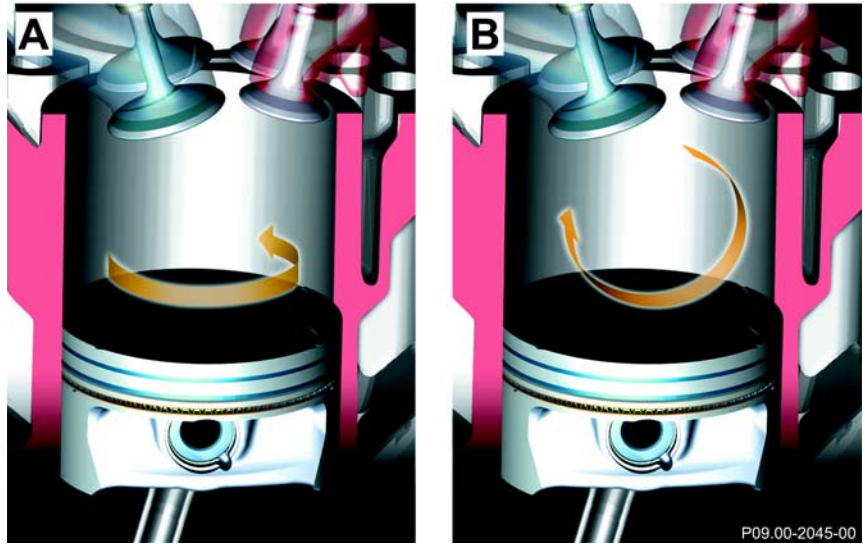

**Charge movement in the cylinder**

A Swirl  
B Turbulence

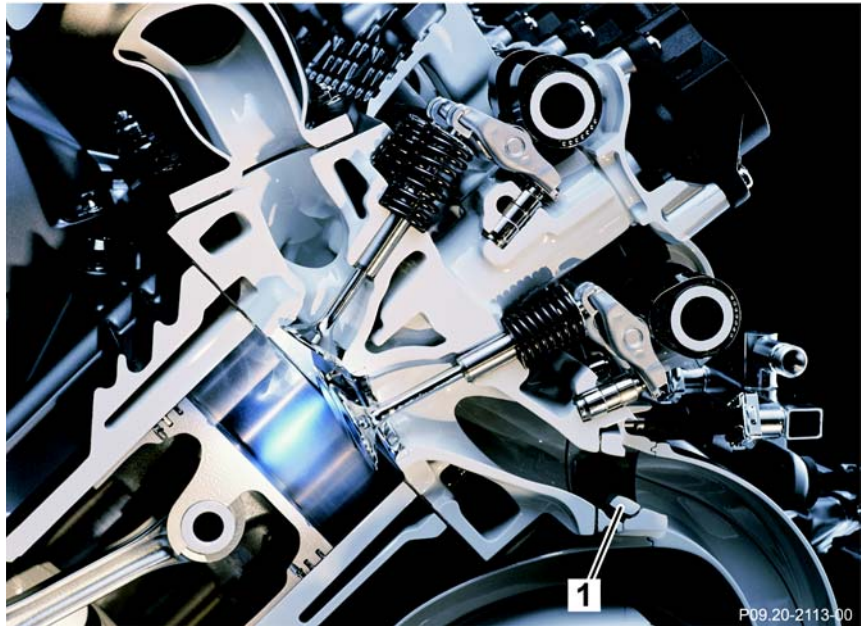

**Turbulence flap in the intake manifold**

1 Turbulence flap

# Engine 272 - Combustion

## Secondary Air Injection (AIR)

The excellent exhaust emissions of the M 272 is achieved in part by secondary air injection with increased throughput.

Secondary air injection in the ports of the cavity-insulated exhaust manifold results in after burning of uncombusted gas. This raises the exhaust port temperature, bringing the catalytic converters more quickly up to operating temperature as a result.

The injection points have been determined on the basis of the flow patterns in the exhaust ports of the cylinder head. This ensures more even distribution of the air to all exhaust ports in the cylinder head.

Each cylinder has one injection point per exhaust valve.

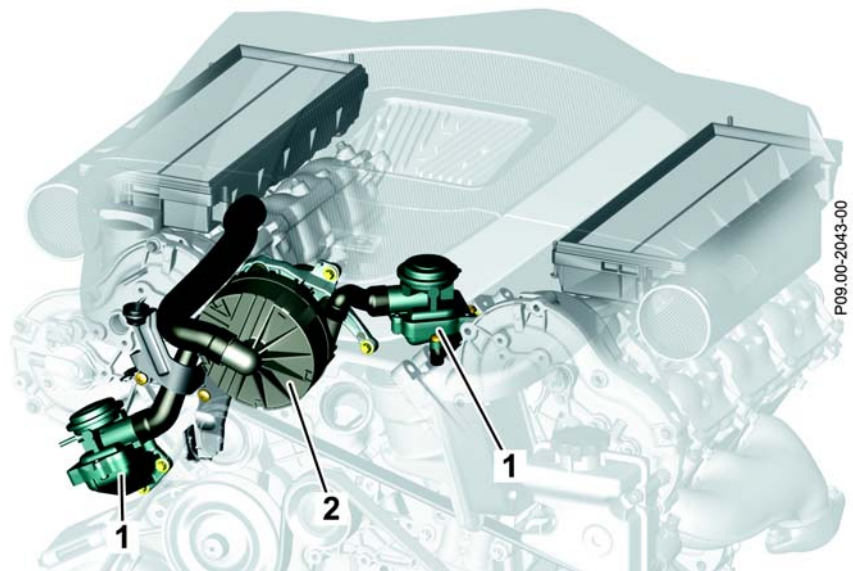

### Secondary air injection

- 1 Secondary air injection combi-valve
- 2 Electric AIR pump

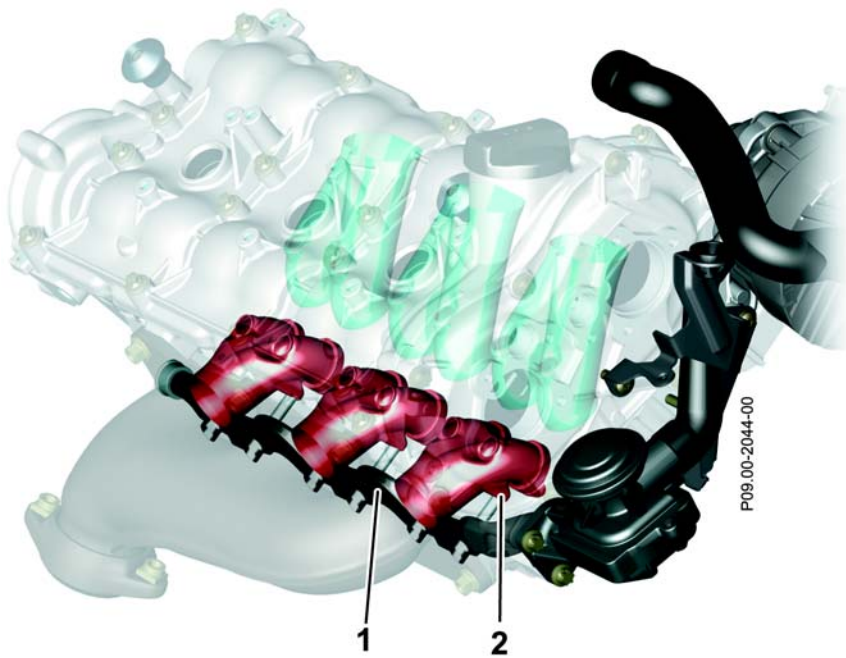

### Injection points in the cylinder head

- 1 Air duct
- 2 Injection points

## Emission controls

### Environment

The elaborate measures taken for emission controls including monolith coating of the catalytic converters fulfil the LEV II limits.

The exhaust manifold has a double-flow design with two walls (cavity insulated).

### Catalytic converters

Catalytic converters fitted close to the engine, each with 1.4 l volume, have the following benefits:

- Improved light-off in the catalytic converters,
- Long catalytic service life
- Reduction of high-frequency structure-borne noise.

### Oxygen sensors

Each of the two catalytic converters has a control sensor and a guide sensor.

Thanks to the linear control of the control sensor they supply the engine control module with precise data about the exhaust gas composition immediately after a cold start. The engine control module then adjusts the ignition timing so that the catalytic converters quickly reach their operating temperature.

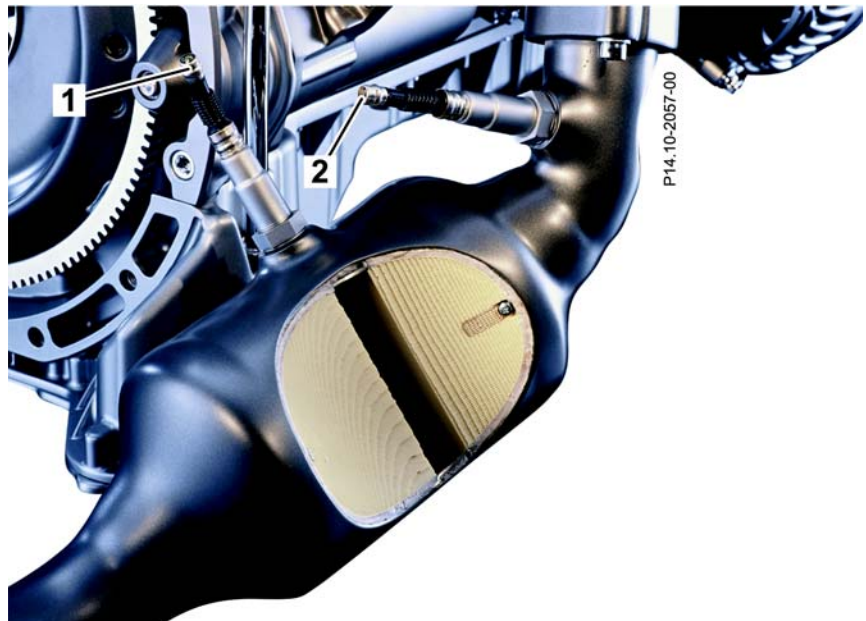

**Catalytic converter mounted close to engine**

- 1 Oxygen-guide sensor
- 2 Oxygen-control sensor

# Engine 272 - Cooling and lubrication

## Engine lubrication

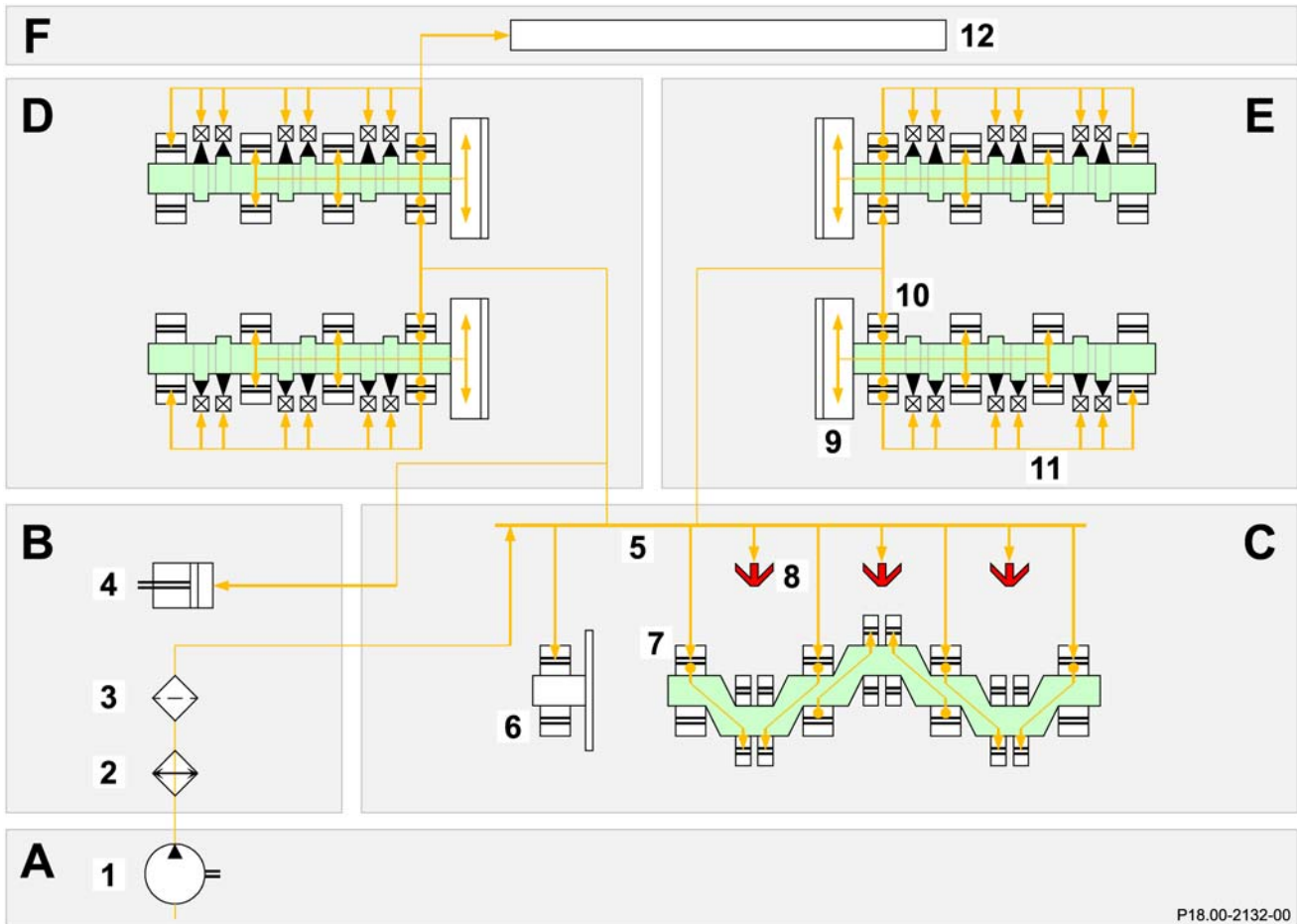

### Lubricating oil circulation

- A Oil sump
- B Timing cover
- C Crankcase
- D Cylinder head, right
- E Cylinder head, right
- F Special units

- 1 Oil pump
- 2 Engine oil cooler
- 3 Engine oil filter
- 4 Timing chain tensioner
- 5 Main oil duct
- 6 Balancer shaft bearing
- 7 Crankshaft and con rod bearing

- 8 Oil injection jets, piston
- 9 Camshaft adjuster
- 10 Camshaft (intake/exhaust) bearing
- 11 Hydraulic valve lifters
- 12 Bearing lubrication, vacuum pump

The camshaft is hollow inside and uses this cavity to supply the camshaft adjusters and their two center bearing points with lubricating oil. The rear bearing position is supplied via a bore hole in the cylinder head.

Lubricating oil is taken from the left cylinder head for the bearings of the vacuum pump which is fitted in some engine versions.

### Engine cooling

#### Triple-plate thermostat

The new heat management system contributes to the lower fuel consumption of the M 272.

A new type of electronic map-controlled triple-plate thermostat controls the flow of coolant around the engine in all operating conditions. The opening temperature of the triple-plate thermostat can be actively controlled by a heating element in the expansion cartridge.

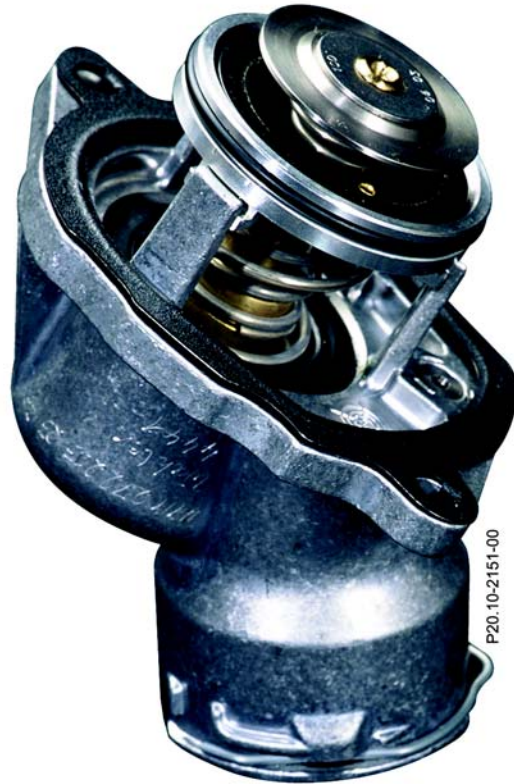

*Triple-plate thermostat*



*Triple-plate thermostat (Y110)*

1 Heating element with electrical connection

# Engine 272 - Cooling and lubrication

## Triple-plate thermostat operating modes

### Short-circuited coolant

In a cold start when the duo or heating cut-off valve (depending on type) is closed, the coolant remains short-circuited in the engine in the coolant cycle. The coolant pump "stirs" the coolant.

**Advantage:** The engine achieves its operating temperature more quickly.

### Raised coolant temperature

In a warm engine at part-throttle the coolant temperature can be raised to around 100 °C. At full-throttle and in temperature-critical operating conditions the coolant temperature is lowered (80 °C in summer / 90 °C in winter).

**Advantage:** The engine is designed to run at the optimum temperature, even at very low or very high loads.

### Reducible engine short circuit

The triple-plate thermostat reduces the coolant flow through the engine to allow a greater quantity to flow through the heating system heater.

**Advantage:** A highly effective heating system which reacts quickly.

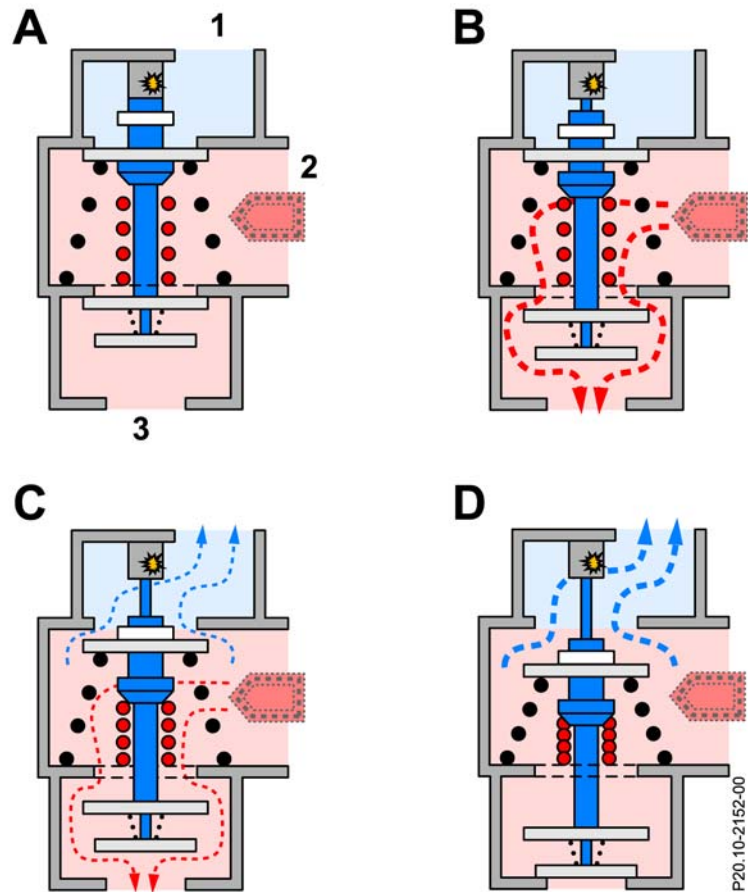

**Triple-plate thermostat operating modes**

- A Full reduction
- B Short-circuit mode
- C Mixed mode
- D Radiator mode

- 1 to the radiator
- 2 from the engine
- 3 to coolant pump (short/circuit)

P20.10-2152-00

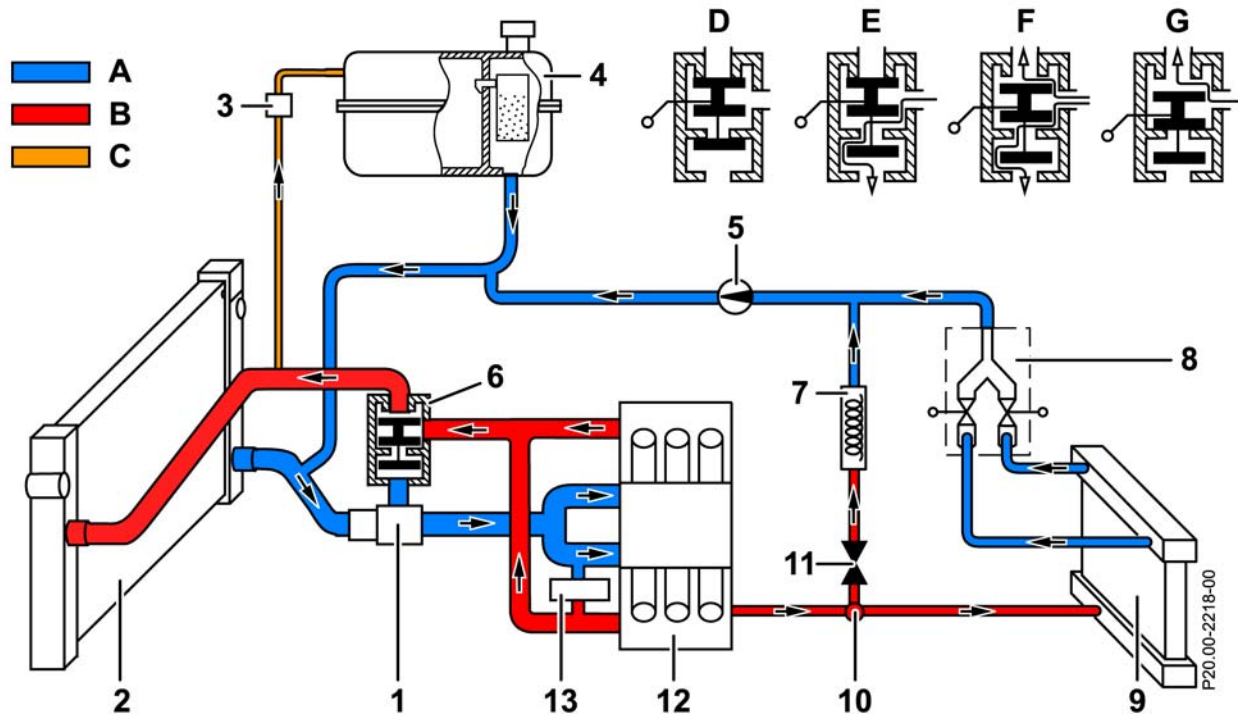

**Schematic coolant cycle, based on R 171 (radiator mode shown)**

- 1 Coolant pump
- 2 Engine cooling, radiator
- 3 Check valve
- 4 Coolant recovery bottle with silica gel
- 5 Electric coolant pump, heating circulation

- 6 Triple-plate thermostat
- 7 Washer water heating
- 8 Duo valve
- 9 Heating system heat exchanger
- 10 Plug coupling
- 11 Shut-off valve
- 12 Cylinder crankcase with cylinder heads
- 13 Engine oil cooler

- A Coolant return
- B Coolant feed
- C Venting
- D Full reduction
- E Short-circuit mode
- F Mixed mode
- G Radiator mode

**Full reduction**

To speed up warming of the engine, the connections to the radiator and the coolant pump (short-circuit) are fully closed. The coolant remains stationary.

**Short-circuit mode**

During the warm-up phase, the connection to the coolant pump is gradually opened until it is 100 % open.

**Mixed mode**

The connections to the radiator and the coolant pump are partially opened depending on the degree of cooling required.

**Radiator mode**

For maximum cooling the connection to the radiator is opened 100 %, the connection to the coolant pump is closed.

**Duo valve/heating shut-off valve**

A duo or a heating shut-off valve (not shown) is fitted, depending on the engine type. These valves interrupt the supply of coolant to the heating system heat exchanger to warm up the engine more quickly.



## Engine 272 - Engine electrical/electronics

### Engine control

Engine management of the M272 is done by the engine control module, the ME 9.7.

To help achieve short electrical paths, the engine control module is mounted on the induction pipe of the engine, i.e. it is an integral part of the engine design. The mounting of the control module on the engine also offers benefits in production.

As with the M 271, the M 272 also features a two-computer design engine control module.

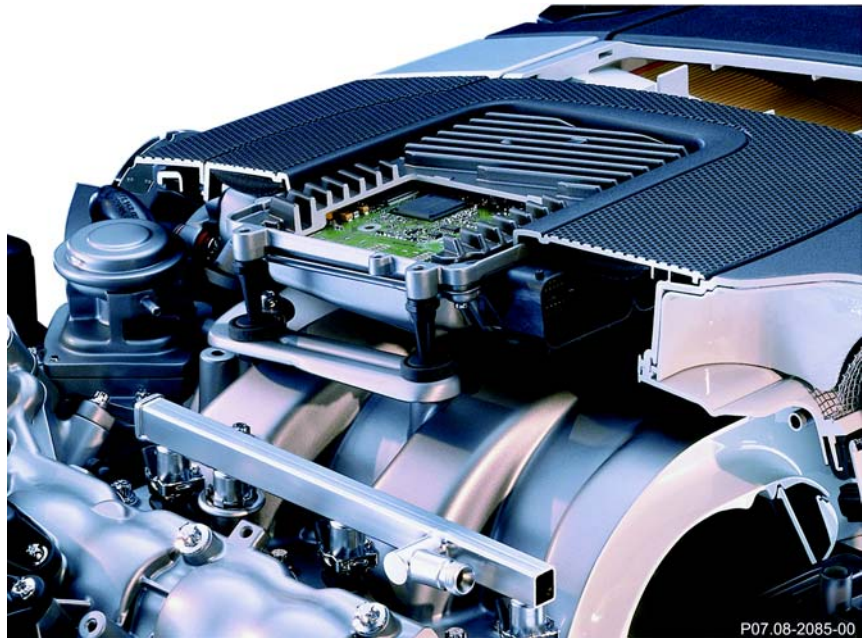

P07.08-2085-00

### Knock sensor

Two knock sensors, one per cylinder bank, detect any combustion knock. The sensors are piezoceramic and correct the ignition timing as required.

*Engine control module mounted on intake manifold*

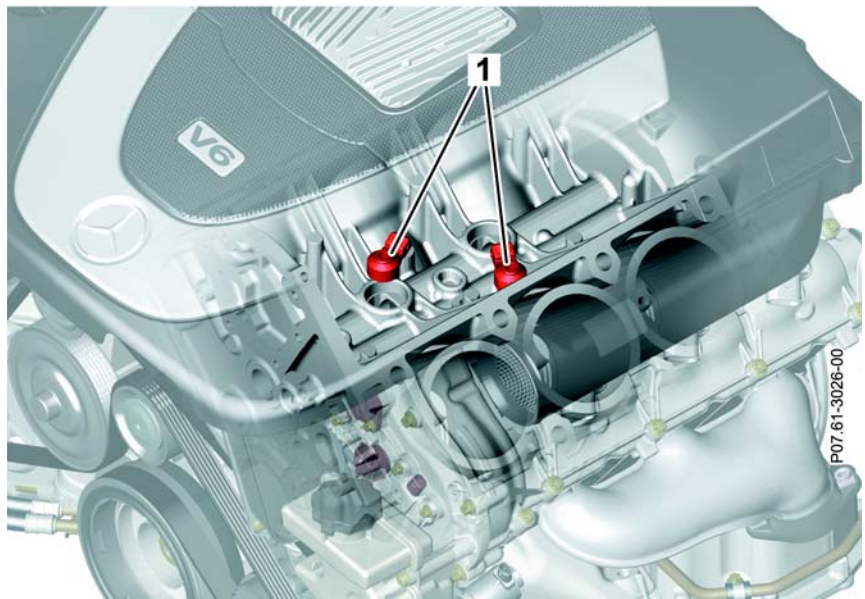

P07.61-3026-00

*1 Knock sensors*

### Coil

Individual coils with integrated ignition output stage are used in the M 272. The coils are controlled by the engine control module via a dedicated control lead.

### Generator interface

The generator communicates with the engine control module via the LIN bus.

This means that the engine control module can influence the control action of the generator by prescribing a target control voltage. Conversely, the generator also signals any errors to the engine control module.

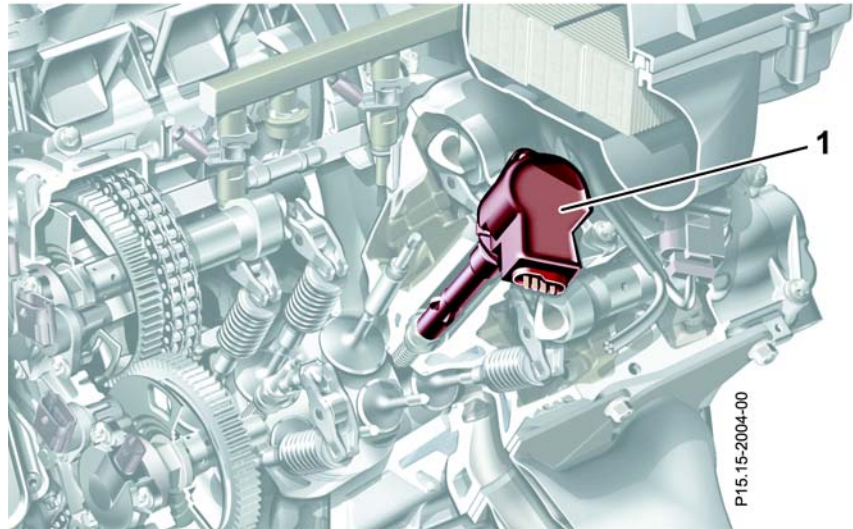

1 Coil

#### **i** LIN-bus

LIN stands for **Local Interconnect Network**.

The LIN bus is a bi-directional single-wire interface with a maximum transmission rate of 20 kbit/s.

The LIN bus links up intelligent engine components which do not require high data transmission rates.

## Engine 272 - Exhaust system

The engine of the 6-cylinder version satisfies the US exhaust emissions limits. To meet these limits the monolith coating of the catalytic converters has been modified (platinum/rhodium plating instead of tri-metal coating). The longevity of the exhaust system is provided by the use of stainless steel throughout.

The exhaust system features a gap-insulated exhaust manifold as well as a bulkhead catalytic converter and one front muffler on each side. Downstream of the separation point behind the front mufflers, the two exhaust streams are combined briefly before traveling on in twin pipes to the two rear mufflers.

The tailpipes feature chrome-plated covers.



P49 00-2058-00

*Exhaust system*

### Fuel tank

The new SLK is fitted with a fuel tank made of two-layer sheet steel and with a capacity of 70 l, which is located above the rear axle. The external shapes of the fuel tank and filler neck have been modified to suit the new installation conditions.

The in-tank fuel feed system operates at a system pressure of 3.8 bar (engine 272) and consists of:

- Fuel pump assembly with fuel level sensor
- Fuel filter with fuel pressure regulator

The fuel flows from the fuel pump assembly via a fuel line to the fuel filter with fuel pressure regulator. In order to supply the fuel pump assembly with sufficient fuel, the system incorporates an integral suction jet pump (at the bottom of the fuel pump assembly). This is supplied with fuel from the fuel pump assembly via a separate fuel line.

Surplus fuel is siphoned off via the fuel pressure regulator and remains in the fuel tank. The system therefore operates without a return line.

The fuel tank breathes via an integral ventilation system. The ventilation system is connected with an activated charcoal filter underneath the fuel tank.

The housing of the fuel feed module acts as a swirl pot. It prevents the fuel pump from drawing in air when cornering with low fuel levels in the tank.

A fuel strainer (coarse filter) is installed at the bottom of the fuel pump assembly at the feed line to the fuel pump.

The fuel tank has one fuel level sensor. The voltage signal is transmitted to the rear SAM control module which processes the signal accordingly and relays it over the CAN data bus to the instrument cluster.

The vehicle is also equipped with ORVR and fuel system pressure sensor.

### SLK 55 AMG

For use with the 5.5 l V8 engine, the fuel tank was modified with a specific in-tank unit with an increased delivery rate to cope with the power requirements.

Engines 113/272 - Fuel system

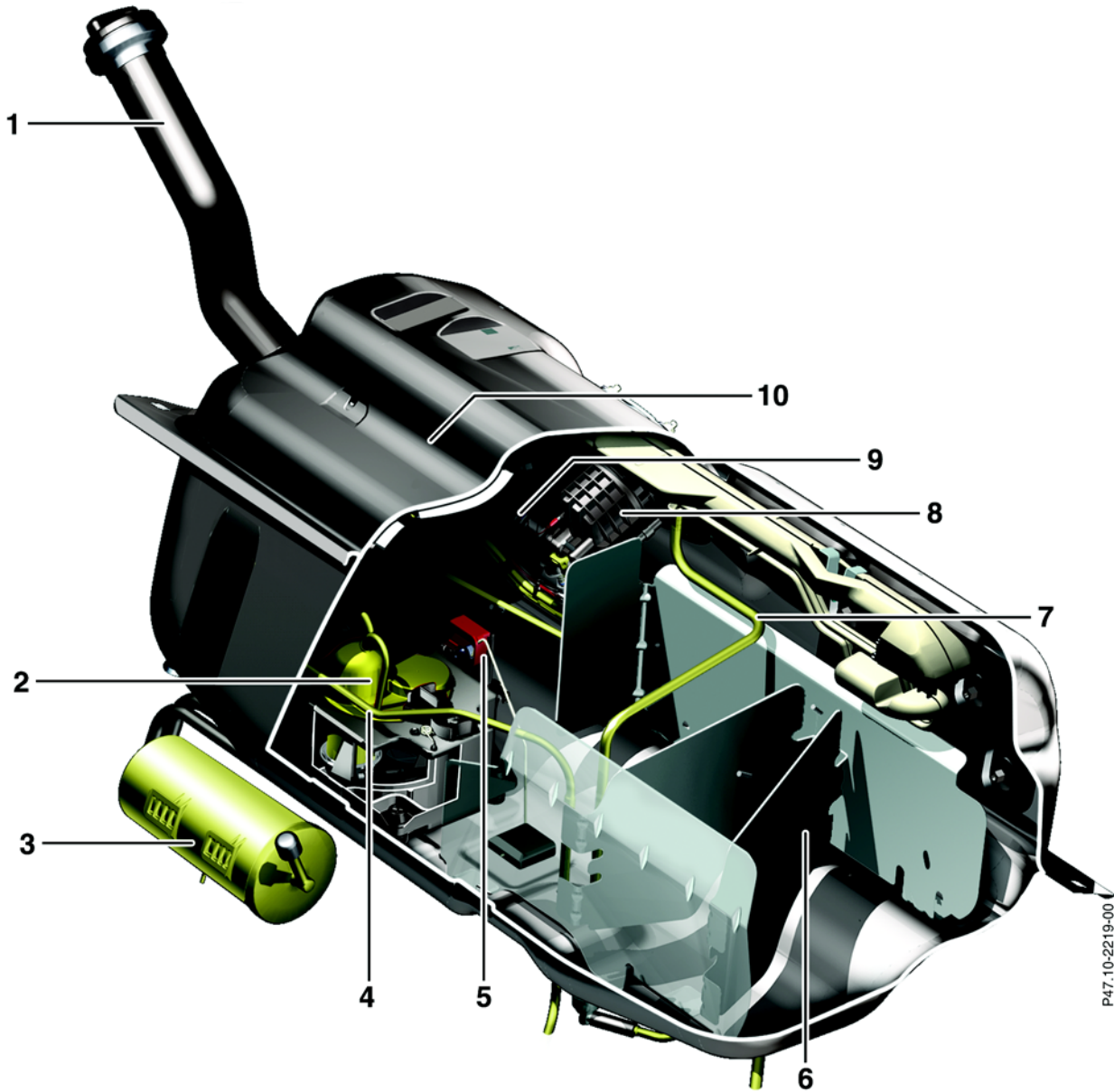

**Cross section of fuel tank (for engine 272)**

- |   |                             |    |                         |
|---|-----------------------------|----|-------------------------|
| 1 | Filler neck                 | 6  | Baffle plate            |
| 2 | Fuel pump assembly          | 7  | Fuel tank vent line     |
| 3 | Activated charcoal canister | 8  | Fuel filter unit        |
| 4 | Fuel line                   | 9  | Fuel pressure regulator |
| 5 | Fuel level sensor           | 10 | Fuel tank               |

## Vehicle dynamics

### Suspension settings

The goal of adapting the suspension to the new SLK was to combine maximum levels of sporty agility and responsiveness with active safety.

The following properties in particular have been improved:

- Steering precision and responsiveness
- Directional and braking stability (even on poor or slippery roads)

ABS with BAS and the more advanced ESP II with ASR are standard equipment on the SLK.

The steering system has been set so that when driving through curves at critical limits, it reacts either neutrally or tends to understeer.

Instead of the previous double wish-bone front axle, a 3-link front axle is installed which is characteristic of this chassis. As in the predecessor model series, independent multilink rear suspension was chosen for its unsurpassed wheel location qualities; its geometry and kinematics have been tuned to make it more sporty in terms of driving dynamics, suspension and damping.

### SLK 55 AMG

The chassis of the AMG roadster has been specially adapted with specific springs, dampers and stabilizer bars, for the enormous power developed by the V8 engine.

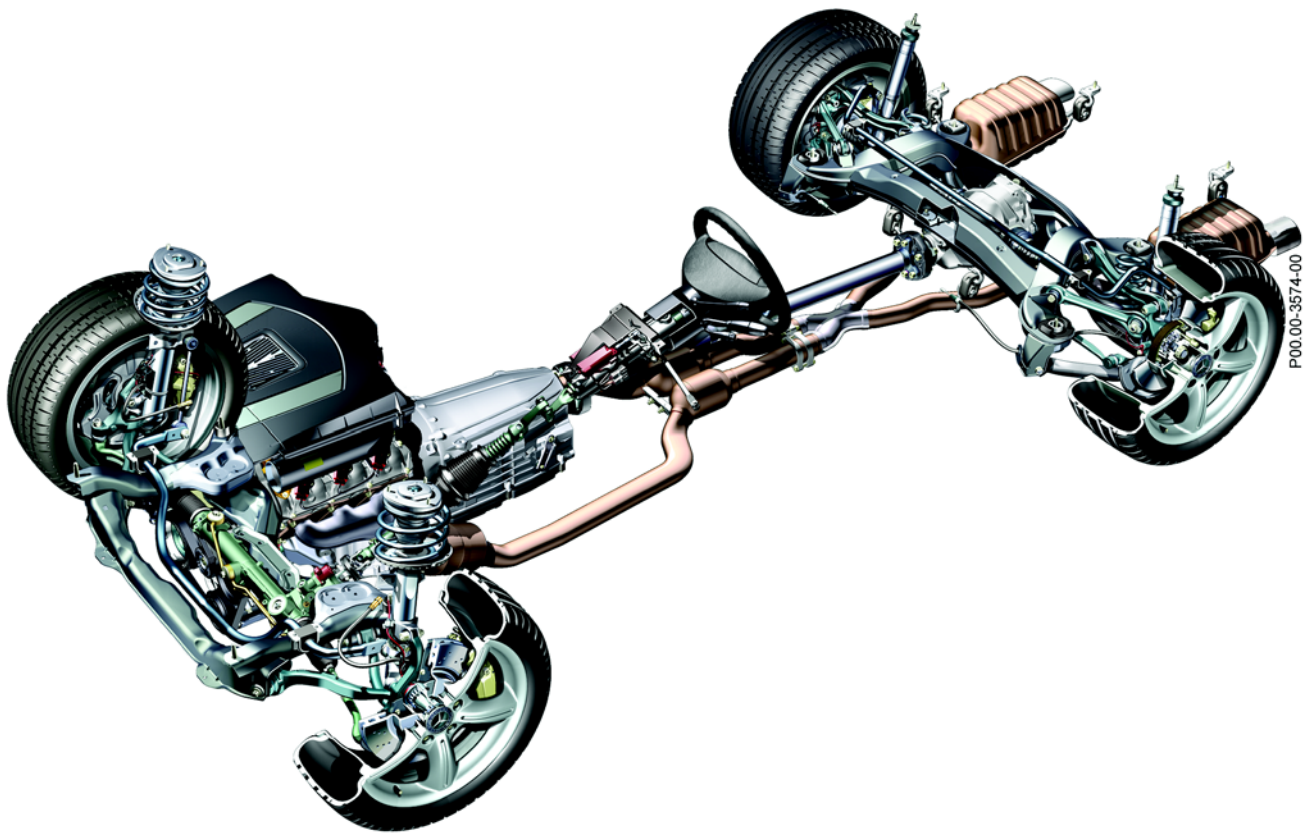

*Location of assemblies on SLK 350*

## Steering

### Rack-and-pinion steering

The new SLK is equipped with rack-and-pinion steering.

The SLK350 features manual steering column adjustment in the longitudinal (+/- 30 mm) and vertical (+/- 25 mm) directions. An electric version (standard on SLK 55 AMG and optional on SLK350) with easy entry feature in conjunction with a memory package is also available.

Further innovations in the steering concept are an electric steering lock coupled to the ignition switch to provide protection against theft and a force-sensitive and speed-sensitive power steering system (speed sensitive power steering is standard on SLK 55 AMG and optional on SLK350).

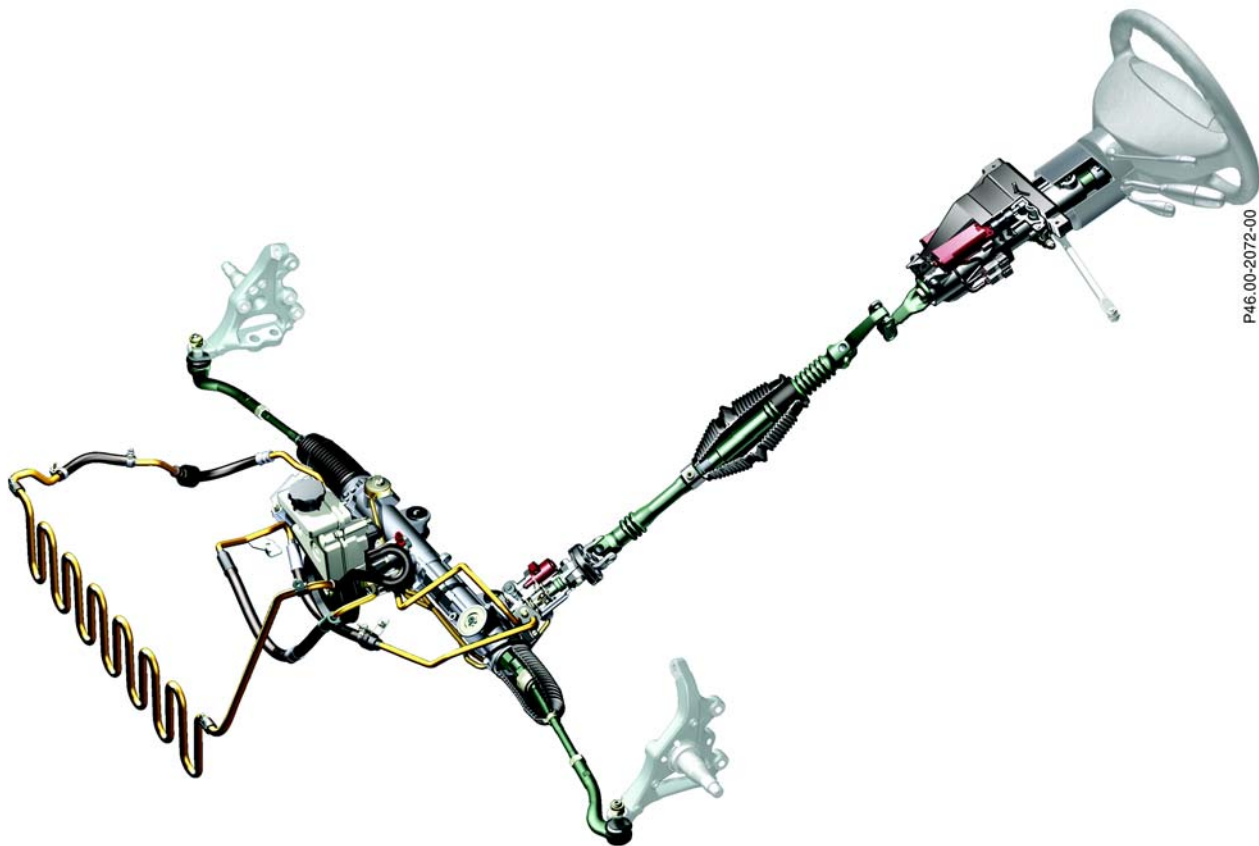

*Steering with steering column and hydraulics*

## Transmission

### 7-speed automatic transmission

The 6-cylinder model can be optionally equipped with a new 7-speed automatic transmission with seven forward gears and two different reverse gear ratios.

#### SLK 55 AMG

The 8-cylinder Mercedes AMG variant is equipped with the newly developed AMG SPEED-SHIFT 7-speed automatic transmission as standard.

Its special features are:

- Quicker shift operations
- Better acceleration
- More responsiveness due to direct downshift by two gears
- Longer service life due to optimized ratio matching
- Significantly increased spread of gear ratios due to seven drive positions
- Reduced fuel consumption and engine noise due to reduced engine speed
- Accurate control of the shift processes due to fully integrated transmission control

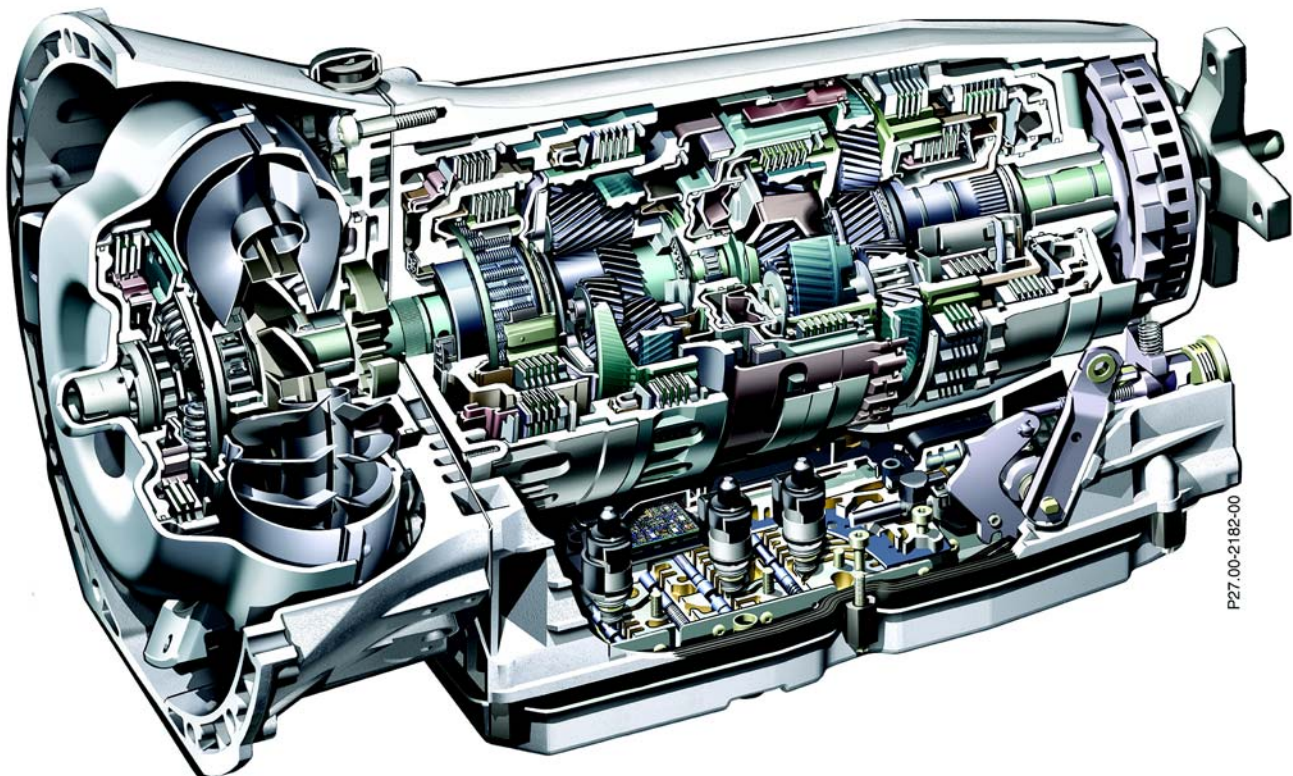

*7-speed automatic transmission*



## Transmission

### 6-speed manual transmission

The design of the 6-speed manual transmission installed as standard in the 6-cylinder model has been significantly optimized; it now operates more directly. It is notable for its improved shifting accuracy and short, quick shift travel distances which underscore its sporty driving characteristics.

The shift/select sequence on the gearshift lever is now transmitted to the transmission by one rod (previously by a shift rod and selector cable). The gearshift lever position for reverse gear is now to the front left and beside first gear instead of to the rear left. A spring loaded reverse gear lockout mechanism must be overcome in order to engage reverse gear. It is no longer necessary to pull the gearshift lever up.

### Steering wheel shift buttons

On the 6-cylinder engine (272) only, a steering wheel gear shift (optional as part of AMG Sports Package) is available for the automatic transmission. The automatic transmission with touch shift has been expanded to include the function "steering wheel shift buttons".

A new feature is that a gearshift can be triggered from within automatic mode by tapping the steering wheel shift buttons, without leaving automatic mode (C or S). If the "downshift" steering wheel shift button is pressed and held down, the transmission automatically shifts to the ideal gear for accelerating. As in the past, this function can also be called up by holding the automatic transmission selector lever to the left.

### SLK 55 AMG

Upshifts are performed with the right steering wheel button and downshifts with the left steering wheel button. In manual transmission mode M an absolute gear selection is possible, i.e. the transmission shifts like a manual transmission:

- On reaching the maximum engine speed it will not shift up automatically.
- On kick-down it will not shift down automatically.

## Axles

### Front axle

A 3-link front axle has been developed, the most important features of which are two individual links (the torque strut and cross strut) which take the place of the lower wishbone. The suspension strut acts as an additional wheel locating element. The third link is the tie rod. The transverse rack-and-pinion steering gear is located in front of the wheel center.

The torque strut is inclined diagonally towards the front and consists of forged aluminum, while the strut lying across the direction of travel is made of forged steel. In contrast to the previous double wishbone axle, the suspension strut also performs other wheel locating functions (McPherson suspension).

The 3-link front axle allows the hood to be flatter and also improves the axle kinematics. It is virtually insensitive to tire imbalance and brake fluctuations. Furthermore, there is a tangible safety benefit in accidents thanks to its longer deformation travel.

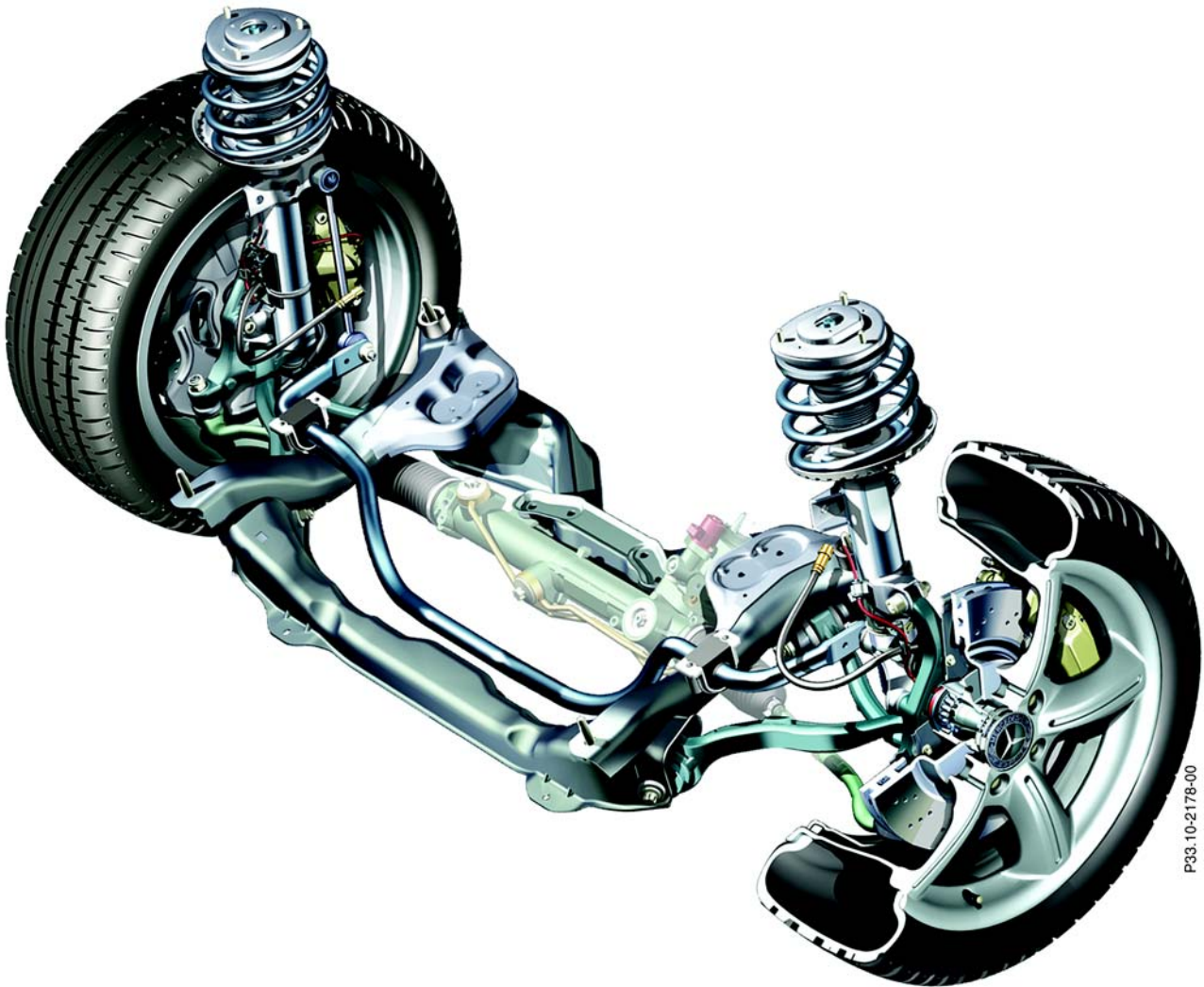

P33.10-217B-00

*Front axle with frame-type integral support*

## Axles

### Rear axle

Because of its unsurpassed wheel location qualities, the principle of the independent multilink rear suspension attached to a rear axle carrier has been adopted from the model series 203 and modified slightly.

The increased track width requires a design modification to the subframe at the front and rear cross braces. The kinematics and elastokinematics of the axle have been optimized.

All models thus feature a stabilizer bar which is fastened directly to the body, but which is installed together with the rear axle carrier.

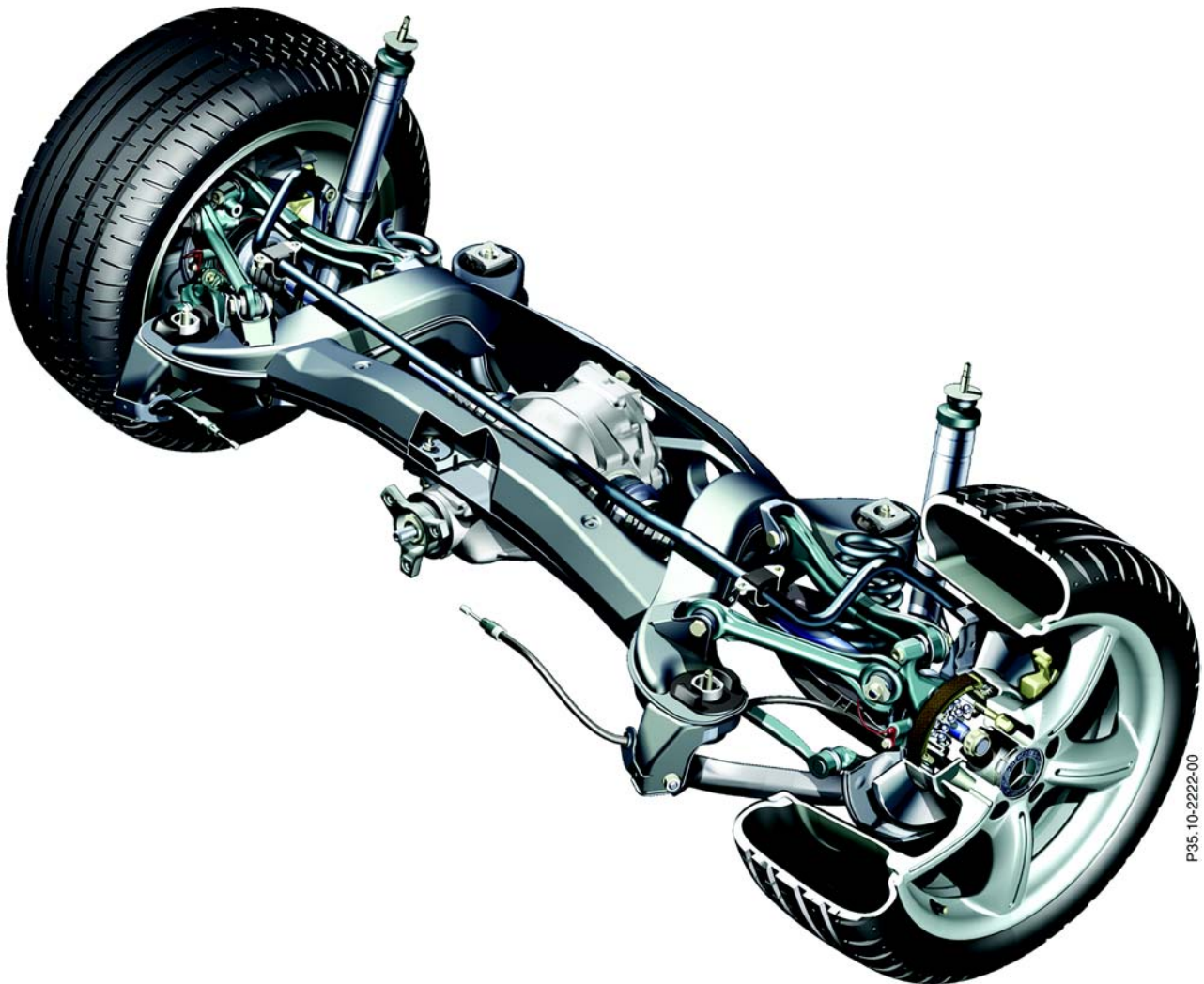

P35\_10-2222-00

*Independent multilink rear suspension*

# Axles

## Rear axle drive

		M 272	M 113
Differential		198	215 FE with heat sink
Side shaft diameter		mm 33 x 5 <sup>1</sup>	
Constant-velocity joint	mm	107	107/116
Gear ratio	$i_{\text{rear axle}}$	3.27	3.06

<sup>1</sup> Hollow shaft (diameter x wall thickness)

## Springs/shock absorbers

### General

On the front axle the suspension struts also perform wheel locating functions in addition to suspension and damping functions. The suspension strut consists of a barrel-shaped coil spring with retracted ends, a 2-pipe shock absorber and a head bearing which has been optimized in terms of height and weight from that of model series 203.

The stabilizer bar is pivoted on the suspension strut by means of a linkage. The linkage joint has been optimized to improve steering response and self-centering.

The stabilizer bar linkage joint is now symmetrical and the ball alignment from top to bottom offers improved kinematics.

To improve the mutual response of the suspension, the front of the stabilizer bar is fitted with vulcanized rubber mounts. It is bolted onto the underside of the longitudinal member with aluminum brackets. The shock-absorber struts on the front axle are equipped with rebound buffer springs to increase the effectiveness of the stabilizer bar during high-speed cornering.

### SLK 55 AMG

The AMG sports suspension employs special suspension struts and shock absorbers which are optimally modified for the enormous power developed by the V8 engine. Responsiveness and vehicle dynamics are further improved by larger stabilizer bars at the front and rear.

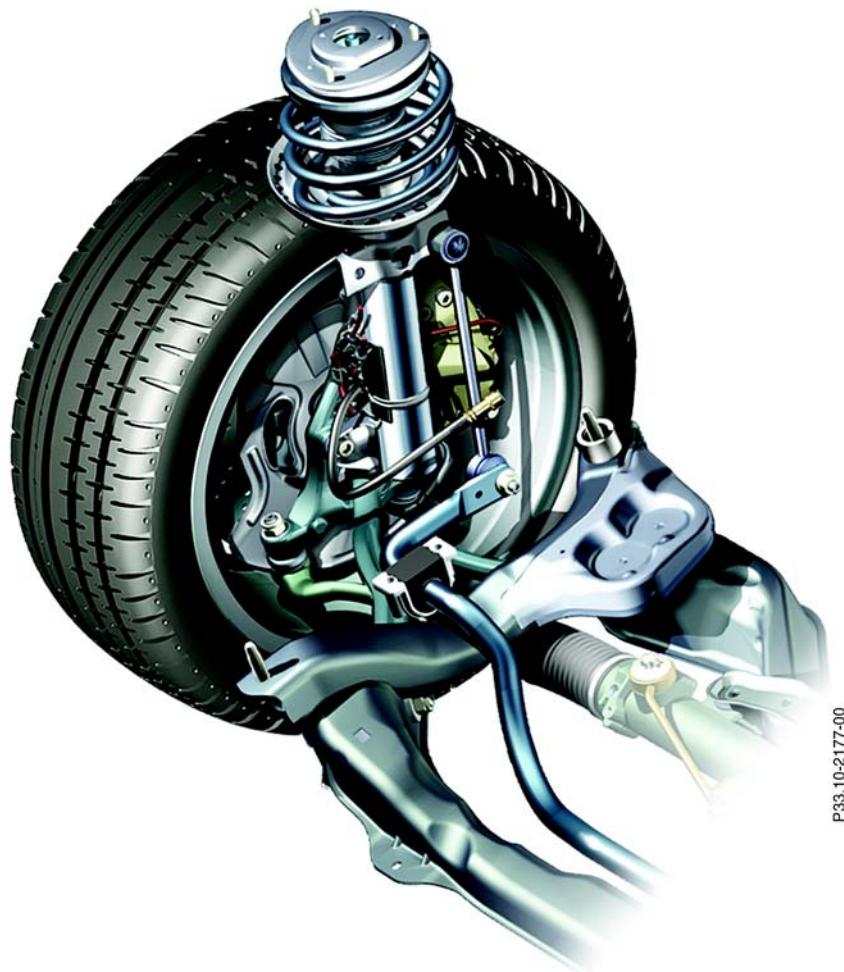

P33.10-2177-00

*Springs/shock absorbers with front axle*

## Brake system

### Brake system

The 6-cylinder variant is fitted with a new, larger front axle brake system of a lightweight construction with cross-drilled brake discs. To improve braking smoothness, front axle brake discs with specially formed cooling fins are used. The brake covers have been optimized in terms of brake cooling and the protection of the brake discs and wheel bearings against splash water has been improved.

The brake unit in use is a 7/8" tandem brake unit with stepped master brake cylinder and brake assist function.

### Parking brake

The lever-type hand brake has been reshaped to save space and fits harmonically in the center console. The lever-type hand brake is equipped with an automatic cable slack adjuster to provide a constant control force.

### SLK 55 AMG

The high-performance roadster is equipped with an AMG high-performance brake system. All the brake discs are cross-drilled and internally ventilated.

The brake system consists of:

- 6-piston aluminum fixed caliper (front) with compound brake discs
- 4-piston aluminum fixed caliper (rear) with one-piece gray iron brake discs

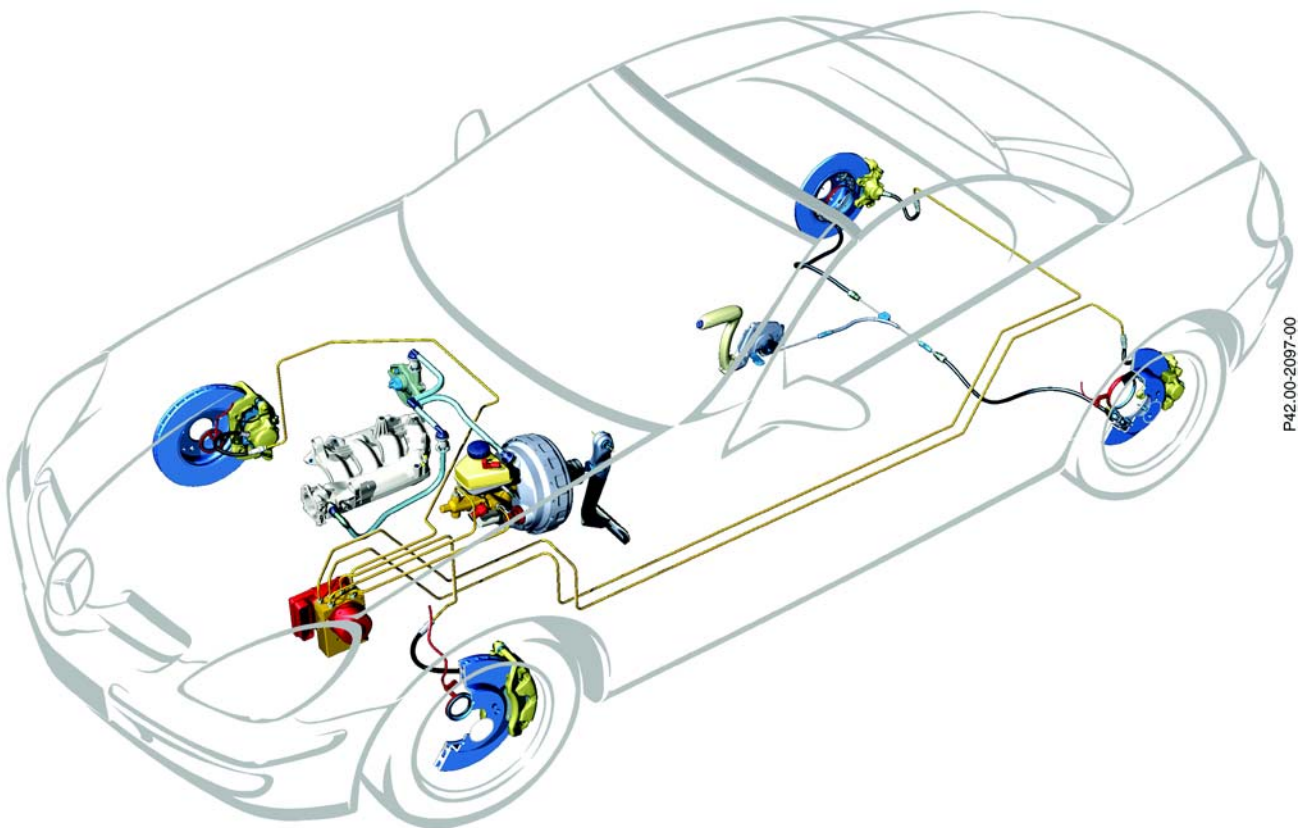

**Brake system**

## Brake system

		SLK 350	SLK 55 AMG
<b>Brake system, front</b>			
Type of brake		4-piston fixed caliper	6-piston aluminum fixed caliper
Wheel cylinder diameter	mm	44/40	30/34/38
Brake disc diameter	mm	330	340
Brake disc thickness	mm	28	32
Version		Internally ventilated, with cross-drilled brake discs	Internally ventilated, with cross-drilled compound brake discs
<b>Brake system, rear</b>			
Type of brake		2-piston fixed caliper	4-piston aluminum fixed caliper
Wheel cylinder diameter	mm	36	26/28
Brake disc diameter	mm	290	330
Brake disc thickness	mm	10	26
Version	mm	Solid	Internally ventilated, with cross-drilled brake discs

Extended vehicle network in the SLK-Class 171

- CAN bus Class B (interior compartment)
- CAN bus Class C (engine compartment)
- MOST bus
- PRIVATE bus

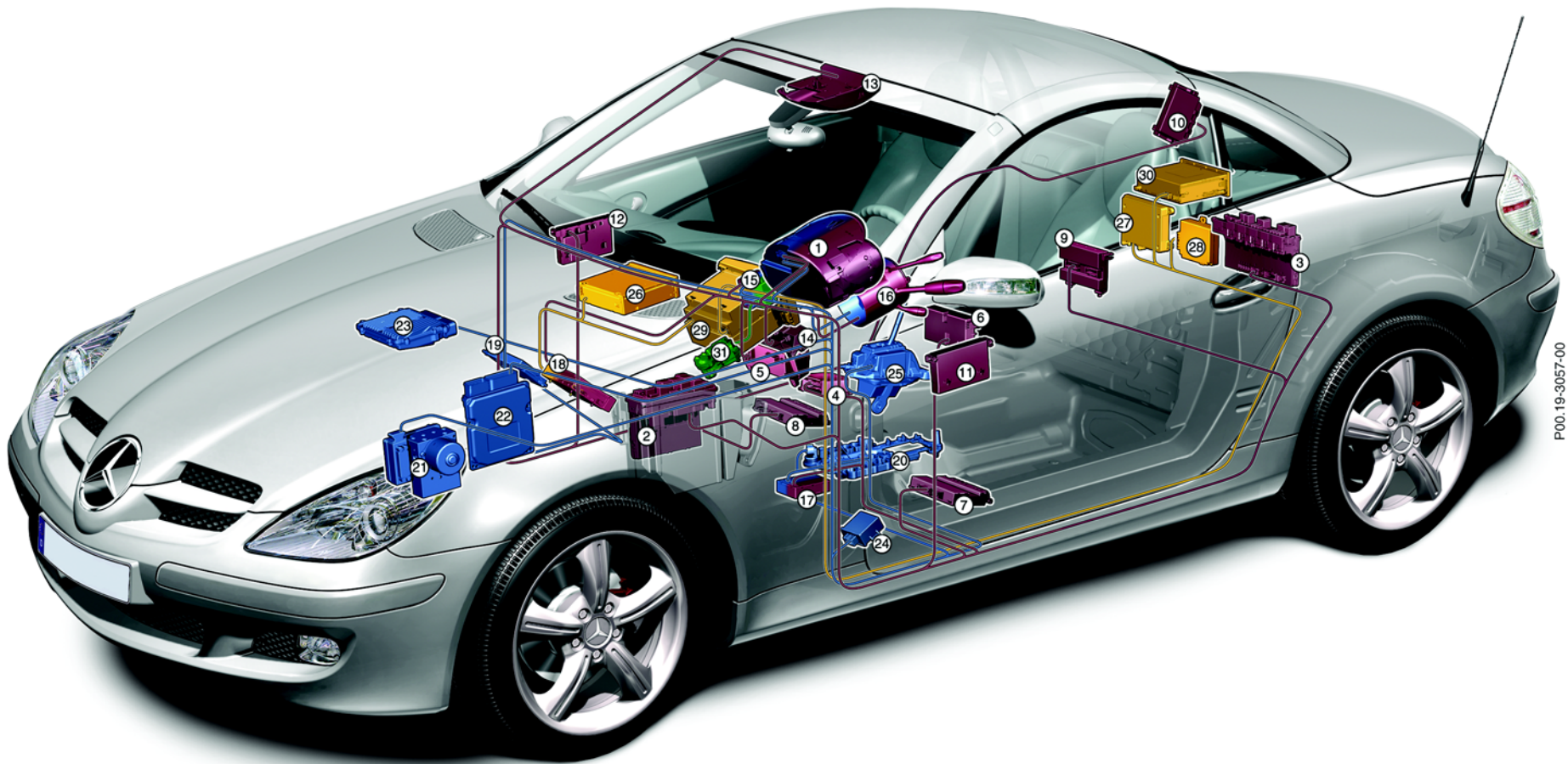

P00.19-3057-00



**CAN bus Class B**

- 1 Instrument cluster
- 2 Driver-side SAM
- 3 Rear SAM and actuation module
- 4 Restraint systems control module
- 5 Automatic climate control (ACC)
- 6 Front heated seats, head area ventilation, (window heater)
- 7 Seat adjustment with memory, driver and steering column
- 8 Seat adjustment with memory, front passenger
- 9 Retractable roof
- 10 Non-US equipment
- 11 Left front door control module (DCM-LF)
- 12 Right front door control module (DCM-RF)
- 13 Overhead control panel (OCP)
- 14 Upper control panel (UCP)
- 15 Electronic ignition switch (EIS)
- 16 Steering column module (SCM)
- 17 Central gateway (CGW)
- 18 Audio gateway (AGW)

**CAN bus Class C**

- 1 Instrument cluster
- 15 Electronic ignition switch (EIS)
- 16 Steering column module (SCM)
- 17 Central gateway (CGW)
- 19 Electronic transmission control (ETC)
- 20 Electronic transmission control (ETC)
- 21 Electronic Stability Program (ESP)
- 22 Non-US component
- 23 Motor electronics M 272
- 24 Headlamp range adjustment (HRA)
- 25 Electronic selector lever module (ESM)

**MOST bus**

- 18 Audio gateway (AGW)
- 26 CD changer (CD-C)
- 27 Multiple Handset Interface (MHI)
- 28 Non-US component
- 29 COMAND or Audio 20
- 30 Navigation processor

**PRIVATE bus**

- 15 Electronic ignition switch (EIS)
- 31 Electric steering lock (ESL)

## Electronic and electrical systems

The networking architecture has been fundamentally renewed in comparison with the predecessor model series.

The main characteristic feature of the new network is the linking of communications/telematics components and vehicle diagnostics with the vehicle network, taking into account foreseeable future developments.

A further highlight of the new network architecture is the expansion of sub-bus systems in the CAN Class B network.

## CAN Class B

New additions include control modules for the following functions:

- Central gateway
- Audio gateway
- ACC operating unit
- Heated seats
- Restraint systems control module

Some of the sub-bus systems employ a single-wire bus (LIN for local interconnect network). Sub-bus systems are used to control a variety of functions including functions in the following systems:

- Steering wheel
- Door
- Climate control/ACC
- Windshield wipers

All the control modules in the CAN Class B network (which in contrast to the CAN Class C network is also available in the "ignition OFF" state) use the internationally standardized OSEK (Open Systems and Corresponding Interfaces for Automotive Electronics) network management system which is capable of integrating up to 64 stations in a single network. This is intended to allow the network to be expanded in the future.

## Networking

### Central gateway

In addition to the diverse data transfer functions between the networks, the CGW also incorporates the following functions:

- System diagnosis
- Service processor
- Maintenance interval display

The complexity of the data network, and the wide variety of functions governed by sophisticated micro-processors in a modern automobile, demand an efficient diagnostic system in order to localize any malfunctions or faults quickly and accurately.

### Mercedes-Benz Maintenance System

The Service processor calculates the remaining time and remaining distance since the last service. In addition, it calculates other maintenance work required.

### CAN Class C

In terms of its physical layout and its baud rate of 500 kbps, the CAN Class C network is similar to the familiar system already in use, which is active only when the ignition is on. As before, the electronic drive management system and the electronic chassis management system communicate with each other over the CAN Class C network. However, the number and functions of the individual control modules have changed from those of the predecessor model series.

The communicating stations include:

- Engine control
- ETC transmission control (automatic transmission only) or easy-shift manual transmission control
- Selector lever module (automatic transmission only)
- ESP control
- Automatic headlamp range adjustment
- Instrument cluster
- Electronic ignition switch
- Steering column switch module
- Central gateway

## Audio and communications systems

### Audio 20 CD and COMAND

The SLK can be fitted with a new generation of audio and telephone systems which are available as optional equipment (alternative or supplemental).

The "Audio 20 CD" equipment includes:

- Single CD player
- Fixed station assignment
- Station search
- Monochrome display
- Telephone keypad

The COMAND equipment includes:

- Two-tuner radio component DVD (CD-compatible)
- DVD navigation
- 6.5" color display
- Telephone keypad
- Tele Aid services (roadside assistance, info, SOS)

Additionally available (optional equipment):

- CD changer in glove compartment
- harman/kardon Logic 7 digital surround sound system (not in combination with Audio 20)
- Motorola digital telephone



**COMAND**

## Audio and communications systems

### Telephone

A multiple handset interface (MHI) (optional equipment) preinstallation with universal interface is available for the motorola digital telephone.

The MHI preinstallation consists of:

- Wiring harness
- Control module
- Compensator
- Contact plate
- Antenna

The MHI full package consists of:

- MHI preinstallation (see above)
- Motorola Portable CTEL
- Portable CTEL holder

The telephone can be operated via the multifunction steering wheel and the displays appear in the instrument cluster.



*Motorola digital telephone*

### Antenna system

The antenna system for the radio, telephone and vehicle remote control consists of a removable mast on the rear fender. The GPS antenna is located in the base of the inside rearview mirror.



P54.00-2430-00

*Antenna mast*

## Audio and communications systems

### CD changer

The available 6-disk CD changer (optional equipment) is equipped with a single feed feature and not with a CD caddy. It is installed in the glove compartment. Only audio CDs can be played.

It is operated via the head unit, which also displays all the active functions:

- Track select (up/down)
- Track/CD play time
- Scan function (plays the first 8 secs. of each track)
- Random track sequence
- Track repeat function

### Speakers

The SLK is fitted with nine speakers as standard equipment:

- 3 speakers in each door
- 2 speakers below the seat belt reels
- 1 speaker (centerfill) in the instrument panel

In order to provide a uniform sound, the volume is increased relative to the vehicle speed (upwards of 20 km/h).

### Digital surround sound system

The harman/kardon Logic 7 digital surround sound system with a power rating of 380 W (optional equipment). This system is equipped with eleven speakers:

- 3 speakers in each door
- 4 speakers on the rear wall
- 1 speaker (centerfill) in the instrument panel

With frequency response compensation matched to the acoustics of the car and tone/volume adjustment via an interior microphone, listening pleasure is uninterrupted with the retractable roof up or down.

#### Note:

Digital surround sound in effect in FM, CD and Satellite radio modes.

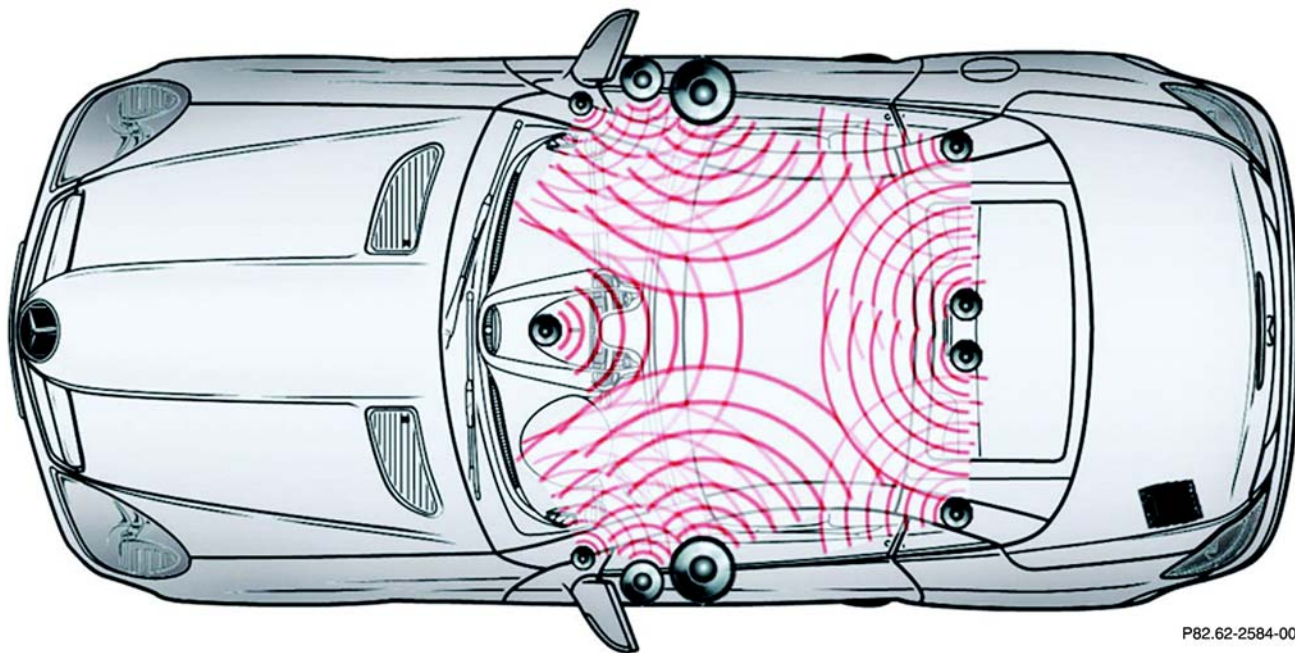

P82.62-2584-00

**Surround sound system speaker positions**

## Retractable roof

### Space-saving storage

Like its predecessor, the new SLK is equipped with the retractable roof. When the retractable roof operating switch is actuated, the SLK changes from a coupé to an open-top roadster (and vice versa) within approx. 22 secs. The opening and closing functions can also be controlled from outside with the aid of a key remote control (optional equipment).

The retractable roof can withstand car washes, is resistant to wear and provides a higher level of protection from vandalism. In terms of environmental comfort and wind noise levels the retractable roof also offers tangible advantages.

The retractable roof system from the predecessor model series has been developed with regard to its mechanical system and space-saving storage in the trunk. A luggage capacity of 6.5 cu. ft. (185 liters) is available in the trunk underneath the stored retractable roof.

### Luggage cover

A luggage cover is installed in the trunk to prevent items of luggage from colliding with roof elements when the roof components are swinging into the trunk. The retractable roof can only be opened when the luggage cover is closed. In order to utilize the full capacity of the trunk with the roof closed, the luggage cover can be folded forward in a single action.



P77.30-2269-00

*Retractable roof movement sequence (shown with accessory wheels)*

## Retractable roof

### System design and function

The retractable roof essentially consists of the pivoting elements which are interconnected by means of a sophisticated pivot mechanism:

- Roof elements
- C-pillars
- Heated rear window

The retractable roof system also includes the trunk lid which, as well as pivoting in the direction of travel, can also be opened in the opposite direction to allow the roof elements to be stored in the trunk.

The actual roof system consists of:

- Twin-shell roof elements comprising steel outer paneling and a steel internal component with roof lining
- Two C-pillars with sheet steel inner and outer shells
- Rear window of 3 mm thick heated single-pane safety glass
- Rear shelf and two side flaps

The right and left pivot mechanisms of the roof are mounted on an aluminum crossmember, which in turn is bolted onto the bodyshell structure in the vicinity of the B-pillar stumps. In addition to the pivot mechanism, this assembly module also includes two electronically controlled hydraulic cylinders for powering the pivot mechanism, the two roll bars and the cylinders for operating the tubular frame.

The hydraulic unit with integral solenoid valve is controlled sequentially via limit switch scanning with overlaid functions. This helps to ensure that the roof can be fully opened or closed within a period of approx. 22 secs.

When closed, the individual elements of the retractable roof are cushioned against each other by means of cellular/soft rubber. The roof elements and C-pillars are positively interlocked in the area of the pivot axis by means of slide valves to prevent the closed roof from being lifted by the wind at the pivot axis at high speeds. It is unlocked via Bowden cables at the front roof catch. In the front part of the roof two latches with a central hydraulic drive lock the roof onto the windshield frame. With the roof closed, wind noise is at the same level as in a coupé.



## Retractable roof

### "Open" or "close" conditions

When the retractable roof is opened or closed, the individual elements travel from their rest positions under hydraulic power and describe defined pivot movements, at the end of which the elements are fully stored in the trunk or are fully closed and locked in the coupé position.

The start conditions for roof actuation are:

- Vehicle is stationary.
- Ignition is switched on.
- Luggage cover in trunk is closed.
- Trunk lid is closed.

If these conditions are satisfied, the retractable roof is opened or closed on actuation of the retractable roof operating switch on the center console.

The opening and closing sequences are aborted if:

- The operating switch is released
- Ignition OFF
- Under voltage in on-board electrical system
- The vehicle is driven
- Over temperature in the hydraulic unit

A total of five hydraulic cylinders are available:

- One for the roof latch
- Two for the roof drive
- Two for the trunk lid drive

The hydraulic pump is a multiple-piston pump with integral electromagnetic valve. It is located near the crossmember behind the seats.

## Retractable roof

### "Open" and "close" movement sequences

Movement sequence until the roof is fully open:

- Front latch on roof/roof frame is unlocked.
- Tubular frame of trunk lid opens automatically towards the rear.
- Rear side windows are lowered.
- Front side windows are moved to the short stroke position.
- Rear shelf folds up.
- Roof is opened.
- Rear window rotates through approx. 150° in the opposite direction to the rotation of the C-pillars.
- Rear shelf folds down and side flaps are extended.
- Roof element, rear window and C-pillars are stored in the trunk.
- Trunk lid is closed.
- Front side windows are closed from the short stroke position.

The retractable roof closes in the reverse sequence.

The remote trunk lid release function remains disabled for the entire duration of the opening or closing sequence.



P77.30-2270-00

*Retractable roof movement sequence (shown with accessory wheels)*

## Retractable roof

### Roll bars

The two roll bars, which are rigidly bolted to the body, function as a safety element. They help to maintain occupant space in a rollover when driving with the retractable roof down. The bars are made of tubular steel and are padded with plastic. They are bolted rigidly onto the assembly module.

### Draft stop

The draft stop is a wind deflector for driving with the roof open. It serves to deflect the turbulent air from behind and reduces drafts at the back of the neck and head. The draft stop is stretched across the two roll bars and is attached to them by means of safety pop fasteners. It is made of fine-mesh synthetic textile fabric.



*Synthetic textile fabric draft stop*

### AIRSCARF head area heating

Another technical innovation is the AIRSCARF neck level heating system (optional equipment) which acts as a thermal draft stop and is available in combination with heated seats and leather upholstery.

**Note:**

AIRSCARF is optional with heated seats and is offered as a package on SLK 350. It is a stand alone option on SLK 55 AMG.

AIRSCARF supplies warm air to the area around the occupants' heads. This makes it possible to drive with the roof down even in cooler outside temperatures.

The fronts of the head restraints have ventilation openings from which warm air can emerge into the head and neck area of the passengers as required.

The air outlet temperature can be set in three stages by means of a switch on the center console. Three indicator lamps (red) in the switch indicate which of the three ventilation settings is selected.

- Stage 0:  
No indicator lamp on.
- Stage 1:  
One indicator lamp on.
- Stage 2:  
Two indicator lamps on.
- Stage 3:  
Three indicator lamps on.

A blower in the backrest provides the necessary outlet speed for the heated air. The outlet speed is adjusted automatically to suit the vehicle speed.

The heating energy is provided by a PTC heating element in the ventilation duct in the backrest.

The air to be warmed flows over slats which are heated with the aid of ceramic posistors.

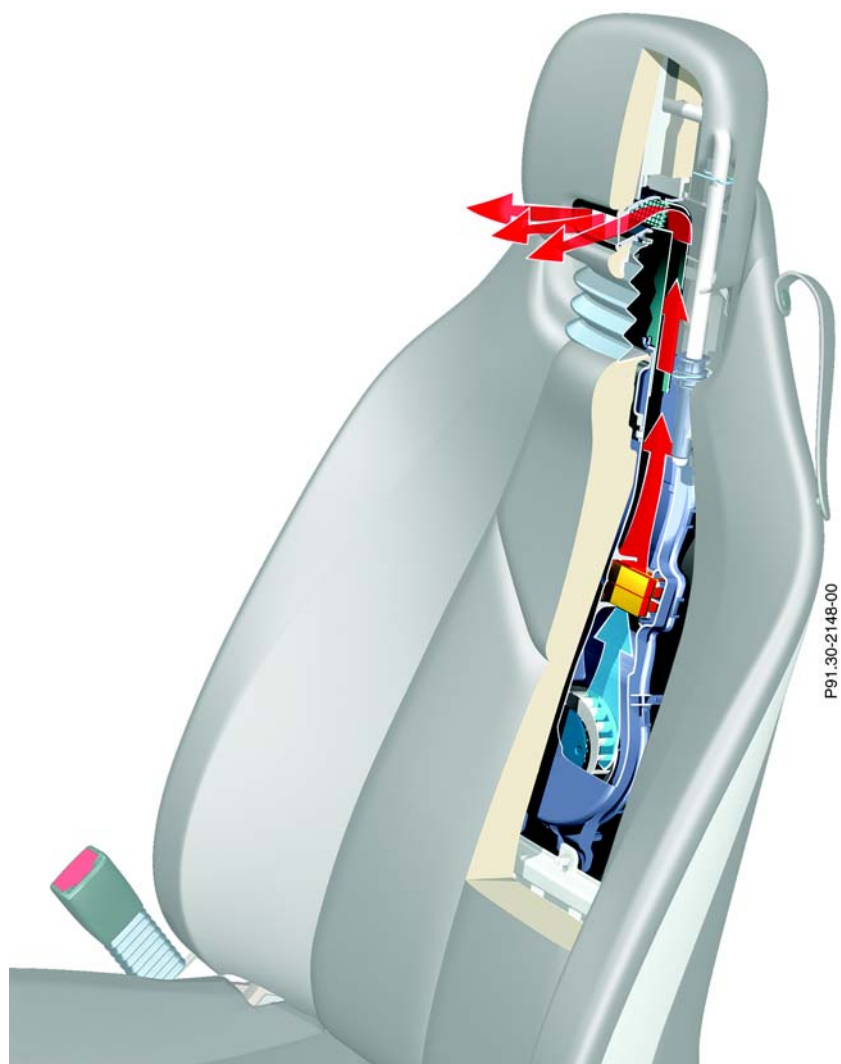

**AIRSCARF**

## Climate control/Automatic climate control

### Climate control/Automatic Climate Control (ACC)

Two variants of interior compartment climate control are available for the SLK:

- Climate control (standard on the SLK 350 and SLK 55 AMG,
- Automatic climate control (optional equipment)

All systems feature separate temperature control for the left and right sides and a recirculated air circuit with dust filter. In the Automatic Climate Control (ACC) system the dust filter is combined with an activated charcoal filter.

### Climate control

The climate control operating unit is a completely new development and comprises a total of four rotary switches with integral pushbuttons.

The rotary switches are used to set:

- Air temperature (driver, passenger)
- Air volume (ten settings)
- Air distribution

The functions of the pushbuttons are as follows:

- Recirculated air
- Residual engine heat utilization with the engine off (REST) and A/C off
- Defrost program with maximum heat output and air stream directed at the windshield.

The climate control system includes an A/C system. The pushbutton with the REST function also performs the additional function A/C<sup>OFF</sup> (compressor cutout).

Additional A/C features:

- Cooling at high outside temperatures
- Automatic adaptation of the recirculated air feature at high outside temperatures



*Climate control module*

## Climate control/Automatic climate control

### Automatic climate control (ACC)

ACC is available as optional equipment.

It differs from the climate control system in the following functions:

- Automatic regulation of air distribution and air volume
- Control takes into account solar, pollutant and dew point sensors
- Temperature settings are stored in the electronic key
- Display in the operating module

### Ventilation

The following ventilation openings are situated in the vicinity of the instrument panel:

- A full-length defroster outlet under the windshield
- An upward-pointing outlet for indirect ventilation of the middle of the passenger compartment (only with ACC)

- Below this, two swiveling outlets pointing into the passenger compartment
- Outside on each side a swiveling side air outlet pointing into the passenger compartment and a fixed side defroster outlet

The following ventilation openings are located in the footwell areas:

- A cross duct with three outlets on the driver side and two outlets on the passenger side



ACC module

## Body

### General

In comparison with the predecessor model series, numerous components of the body shell and the detachable external body parts have been redeveloped for model series 171. These changes were based on internal criteria above and beyond the legal requirements.

The lack of a permanently welded roof structure demands special design measures to meet the usual high standards of Mercedes-Benz sedan cars in terms of rigidity and strength.

Similarly, the body shell structure must offer a solid basis on which to mount the special mechanisms of the retractable roof and the trunk lid.

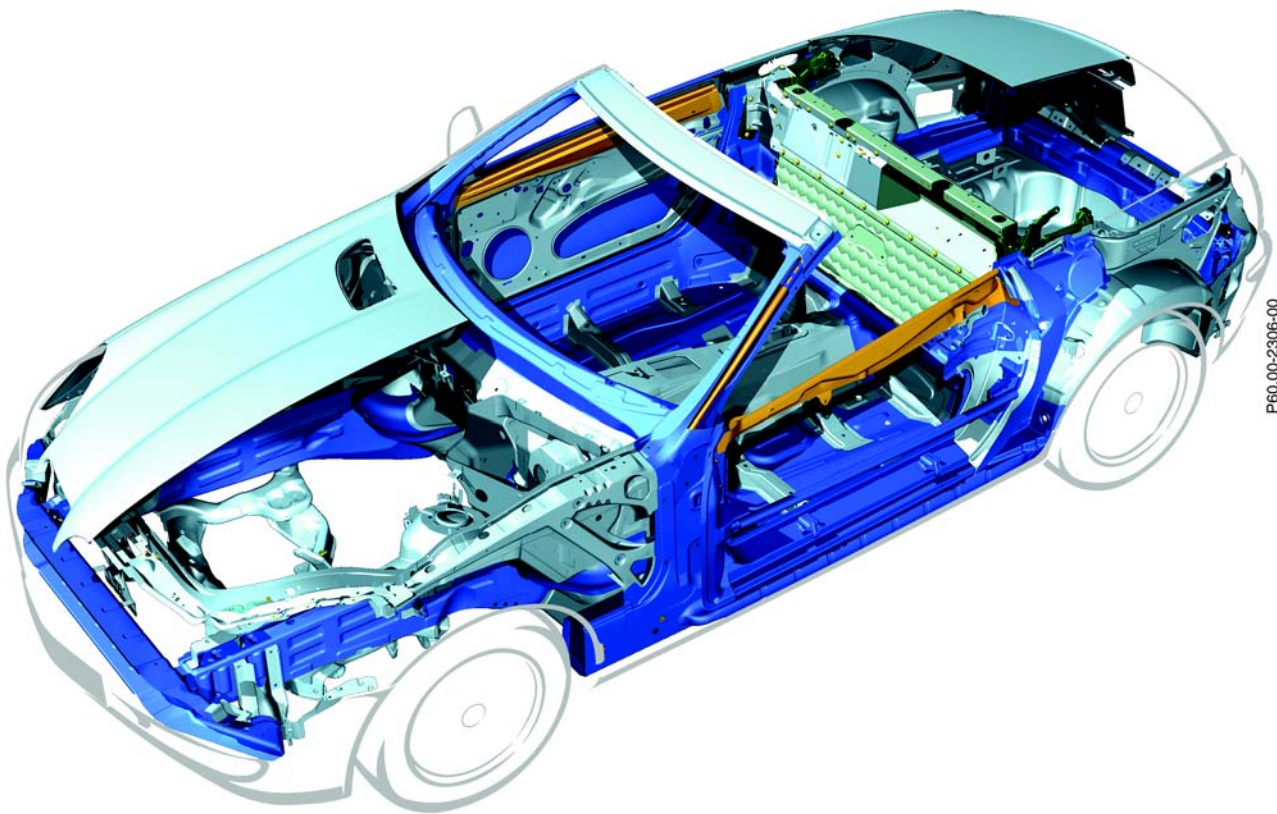

P60.00-2306-00

### Body structure

- *ST 14/ST 13/ST 12/ST 6/ST 5/ST 3*
- *High-strength sheet metal*
- *Aluminum sheet*
- *Aluminum casting*
- *Heat-formed steel*

## Body shell structure

The body shell of the new SLK is a lightweight steel structure.

The following body shell components specific to the roadster are located in the area of the passenger cell:

- Inset tunnel with increased sheet thickness and closing panel
- Straight line end members attached from below on both sides as extensions to the front longitudinal members as far as the rear longitudinal members
- Seat crossmembers on both sides
- Side longitudinal members each consisting of an internal and an external shell with an additional reinforcement attached on the outside
- Extension of the side longitudinal members beyond the A-pillars towards the front acting as additional impact elements
- A-pillar with welded-in oval tube and sturdy gusset plate connections with the side longitudinal members
- Large-surface support of the B-pillar stumps via crossmembers and rear wall
- Tubular crossmember in the form of an assembly carrier under the instrument panel

## Front end structure

The forward structure for supporting the headlamps, the bumper and the radiator is welded to the front longitudinal members.

The frame-type integral support is rigidly bolted onto the two straight line front longitudinal members. The frame-type integral support is composed of four carrier parts in a frame structure. It carries the rack-and-pinion steering gear, the engine mounts and wheel location components. This makes it possible to preassemble and install the major drive assemblies from below. In the event of a severe head-on collision, the longitudinal members (in front of the wheelhouse) and the frame-type integral support can deform while absorbing impact energy.

## Bulkhead

The upper edge of the bulkhead is formed by an additional cross-member. The two front longitudinal members are supported by both the crossmember and the bulkhead. To reinforce these connections, a crossmember is mounted on the two lower bulkhead surfaces on each side of the front longitudinal members to connect the front longitudinal members with the outer longitudinal members and with the tunnel. The metal thickness of each part is individually matched to the local peak stresses.

## Rear end structure

To increase their strength and improve their deformation behavior, the multi-part rear longitudinal members have a cross section which is closed along their entire length with graduated sheet thicknesses and internal stay plates. The steel spare wheel well is part of the rear floor assembly. The rear end of the rear floor assembly is formed by the rear crossmember, which is connected with the rear end center assembly and carries the rear bumper and the tubular frame.



## Body repairs

### Welding work

Riveting has a number of advantages over the "plug welding" method previously used:

- Certain higher- and high-strength steels cannot be welded (with inert gas).
- Different materials can be joined by means of adhesive bonding. The adhesive acts as a "separating layer" to avoid electrochemical contact corrosion.
- There is no risk of corrosion as a result of "burning" the non-metallic coating.
- No structural changes take place in the material as a result of the introduction of heat.
- Providing the jointing is executed correctly, leak-tightness is achieved.

The familiar flat and countersunk head rivets are used.

Screw clamp grips are used for fixing in place the sheets to be riveted together. Like the riveting tool, these are listed as commercially available tools in the Workshop Information System (WIS).

#### **i** Note

The following general rule applies:

The preferred jointing method for steel sheets is spot welding.

Riveting should be used at inaccessible points.

## Body repairs

Package contents	Order number	Sources
Celette USA Dedicated Fixtures for Structural Repairs	325-7171.300	Refer to MBUSA Standard Service Equipment Program (1-888-458-4040)
Welding Fixtures		Refer to Special Tools section